

D-MON®

C-Mon®



C/D-MON™
Data logger for
Geotechnical and
Geological
Sounding methods.

Environmental Mechanics AB
Mr: Kjell Elmgren
Kungegardsgatan 7

S-441 57 ALINGSAS
Sweden

Tel: +46 322 67 03 30
Fax: +46 322 63 67 56
E-Mail: info@envi.se
URL: www.envi.se

General Description.

The latest generation of data loggers for registration of drilling parameters and CPT.

C/D-Mon.

The C-Mon (Cone Monitor) and D-Mon (Drill Monitor) are developed with the latest technology within electronics for the industry.

We have used modern design for the hardware and a completely new way for the ergonomics and the logic for the operator.

The Operative System, owned by us, is build on a kernel from Accelerated Technology Inc. The operative system from AT Inc. is a very intelligent and powerful tool. It is used by the Industry and Scientific world, where too quick changes of the soft wares are impossible. New soft ware for modifications and new methods are done on the AT Inc. Kernel on a very quick and cost effective way. There no license cost for upgrading of new versions. The original soft ware will not be out of date and unusable. The D-Mon will also never be used for Word Processing or playing games. It is a tool for the rig owner.

The handling of the C/D-Mon is totally menu operated. All possibilities at upstart, operation, registration of data and collection of data is clearly described on the screen. All input is done by the wheel and three buttons.

The screen is of new type, giving 700 Candela intensity of light. It guarantees that the screen gives full brightness in full daylight and even when the sun is in zenith. During the dark winter the backlight of the screen gives a perfect picture even when it is 30 degrees centigrade below freezing.

The D-Mon can be mounted on the rig as one unit, with the bottom part, the operative wheel and the screen on it's attachment. It can also be mounted as three separate units. The bottom part with the pressure transducers can be fixed somewhere protected on the rig. The wheel for communication with the logger will be mounted easy accessible near the levers and the screen with most of the electronics, all software and all the memory functions, will be put on the "smart ball". The ball makes it easy turnable in almost all angles. At the end of the day, the screen is easily detachable by one big fastening nut and one cable connection. The light aluminium screen is stored in the elegant case, which will also be the transport case protecting the screen from damage.

General.

The D-Mon is fully menu oriented. All information is presented on the screen. Go through the different options with the rotating wheel and make the choice by pressing the button in the centre of the wheel. The **PLUS BUTTON** starts the logging and the **MINUS BUTTON** stops the logging. The **PLUS** and **MINUS** buttons are used for i.e. **ROD CHANGE**.

<i>D-Mon</i>	Tuesday 14 January 12:19
	Main menu
	Sounding
	System functions
	Data transfer
	Settings
	Monitor setup

Connect the Main Cable and the D-Mon will automatically start. The first picture on the screen is the Main menu. Apart from product name and Logo, you find five pop up menus.

Sounding	Here you change between the different sounding methods programmed in your D-Mon.
System functions	Here you have all directories and the manoeuvring of the floppy hatch.
Data transfer	Here you have the functions for downloading of data in several ways.
Settings	Here you have the different settings for your D-Mon
Monitor setup	Here you have the different setups for the D-Mon and the sensors.

Monitor setup

This chapter is for the producer and different set ups.

<i>D-Mon</i>		Tuesday 14 January 12:19
		Setup menu
		← Back
		Setup from floppy
		Setup to floppy
		Language
		Load Logo
		Set company name
		Sensor setup
		Sensor calibration
		I/O display
		System info
		Unlock program
		Set serial no
		Set unique id
		Set phone no
		Burn in test

Setup from floppy

Input for the specifications valid for your rig type.

Setup to floppy

Download of the installed specifications for your rig type.

Language

A selection of the different communication languages available in your D-Mon.

Load logo

There are possibilities for different logo-types at the start page. Also different screensavers can be installed.

Set company name

Type our own company name. This will be presented in the head of every data file.

Sensor setup	Setup for the different transducers and sensors used on the specific rig.
Sensor calibration	Calibration of the different transducers and sensors used on the specific rig.
I/O display	Shows all un calibrated data from the transducers and sensors installed on the specific rig.
System info	This gives you the Serial number and soft ware version installed.
Unlock program	Opens the D-Mon for the first time, for downloading of all necessary soft ware. Also when programs for new methods will be downloaded.
Set serial No	This option is protected by a password and only accessible by the producer.
Set unique id	Puts an internal number on every file.
Set phone no	Print the number to the e-mail server.
Burn in test	This is used for the final long term test of all functions of the data logger.

Settings

<i>D-Mon</i>	Tuesday 14 January 12:19
	Settings menu
	← Back
	Backlight level
	Colours
	High/Low limits
	Date and time

Back	This choice takes you back to the previous picture.
Backlight level	Here you adjust the intensity of light on the screen. When the symbol comes up, adjust with the wheel and confirm with the centre button.
Colours	There are two ways of having the screen set up. The default with dark letters and markings on the light screen or a dark background with lighter letters. The choice is individual . In different light conditions you can achieve better visibility by changing between these two options.
High/Low limits	For individual programming of maximum and minimum values presented as different colours on the screen.
Date and time	set year by turning the wheel select month set date by turning the wheel select day set hour by turning the wheel set minutes by turning the wheel

Data transfer

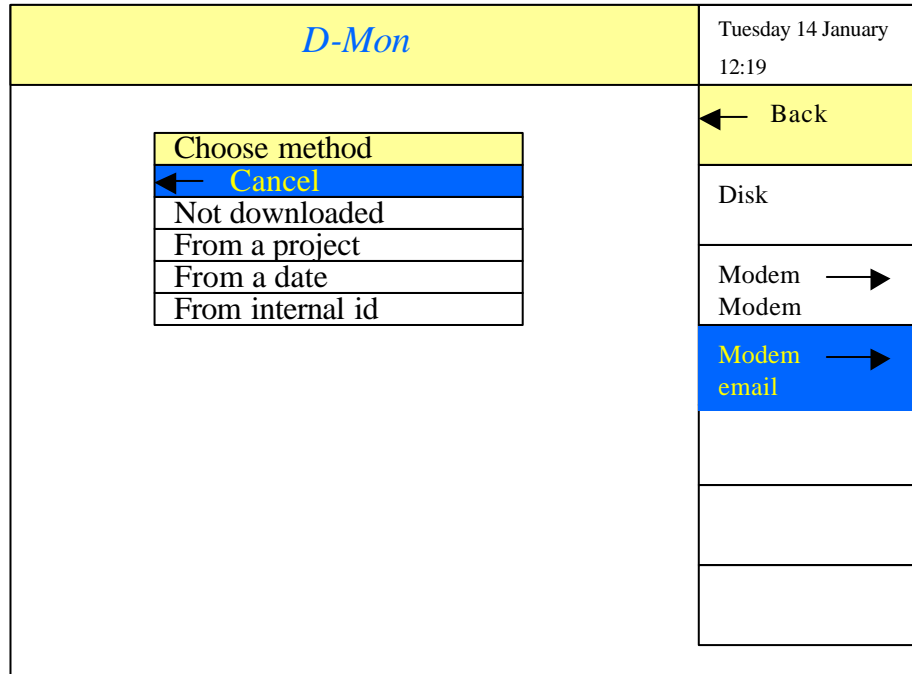

Back	Takes you back to the main menu.
Disk	Down load the data to a floppy disk or an USB memory. The installed media is decided at the "Monitor setup".
Modem to Modem	Down load the data to a connected modem. This is plugged in to the RS 232 in the MemoCone plug.
Modem to email	If the cell phone module (GSM module) is connected and the pre-chosen server-number is programmed.

Cancel	Takes you back to the main menu
Not downloaded	When a sounding has been downloaded once, it gets a mark on the file. This choice will download all files that has not been downloaded before.
From a project	When starting a new sounding up the D-Mon asks for a Project name. This choice search the entire hard disk drive for all soundings made under the same project name.
From a date	When starting a new sounding the date will always be included in the file. This choice search the entire hard disk drive for all soundings performed on a specific date.
From internal id	Every sounding gets an internal number, starting from 0001. If the operator knows this internal number, this sounding can be downloaded again.

The internal memory saves always the last 3 000 meters of soundings in the revolving hard disk drive.

System function

<i>D-Mon</i>	Tuesday 14 January 12:19
	System menu
	← Back
	Soundings directory
	Open floppy hatch
	Closing floppy hatch

Soundings directory From this option you download soundings stored in the hard disk drive.

The choices are: Latest, where you get the last 20 soundings listed.

From a project, where you write in the project name using the wheel on the keyboard on the screen.

From a date, where you write in the date following the instructions coming up on the screen.

Open floppy hatch With this choice, the hatch covering the floppy disk, is opened for access to the floppy disk station.

Close floppy hatch The water and weatherproof hatch will automatically close.

Setup for CPT with the ENVI MemoCone II.
Data logger C-Mon.

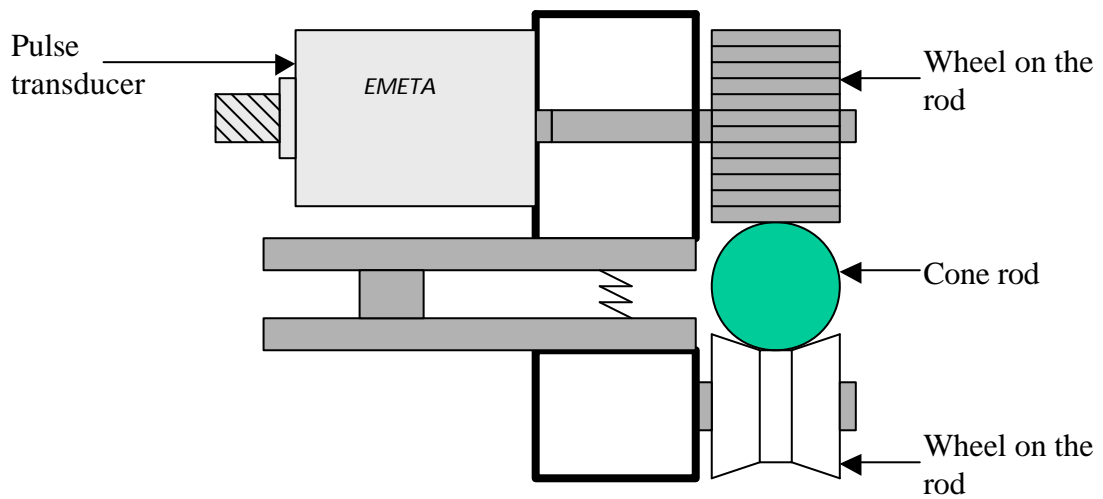
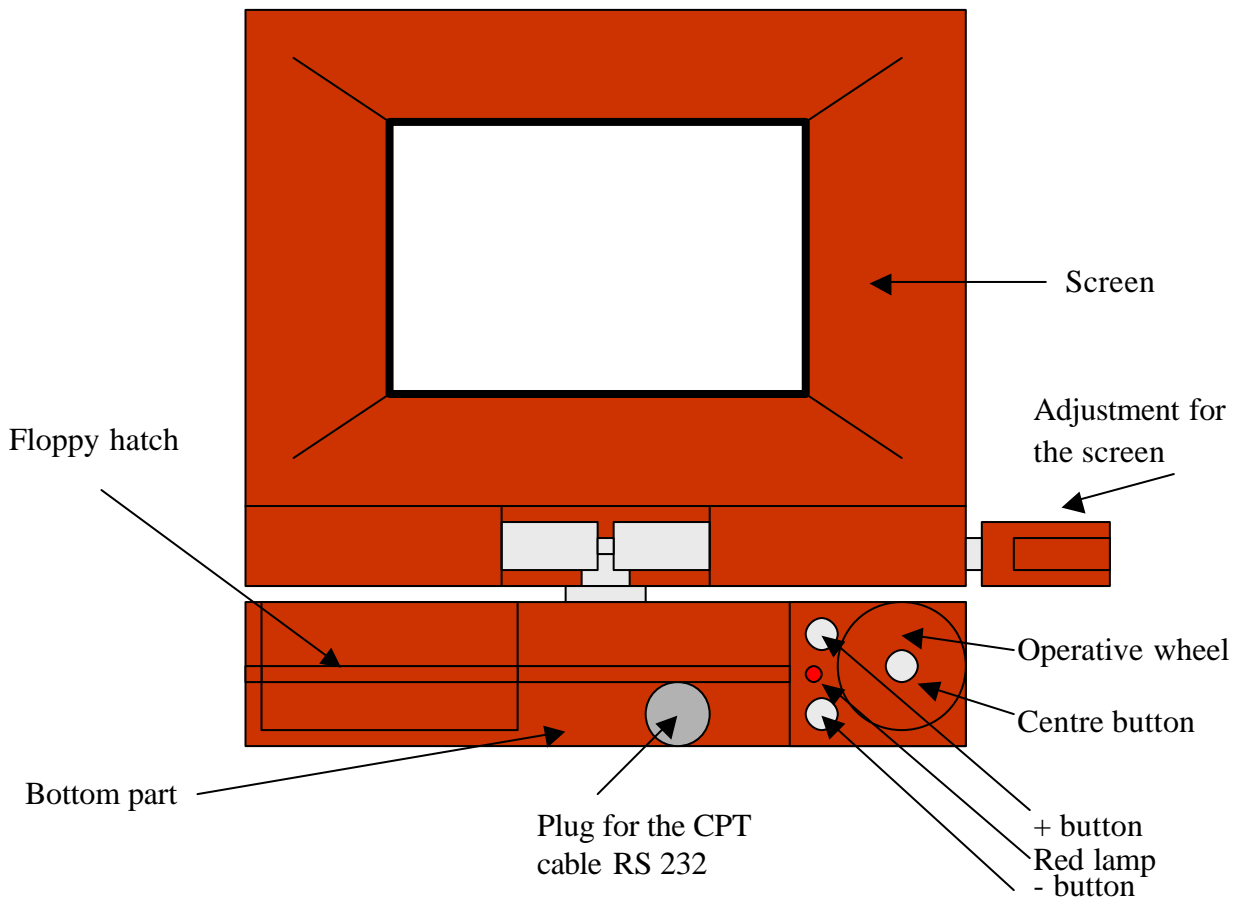

Depth registration "wheel on the rod".

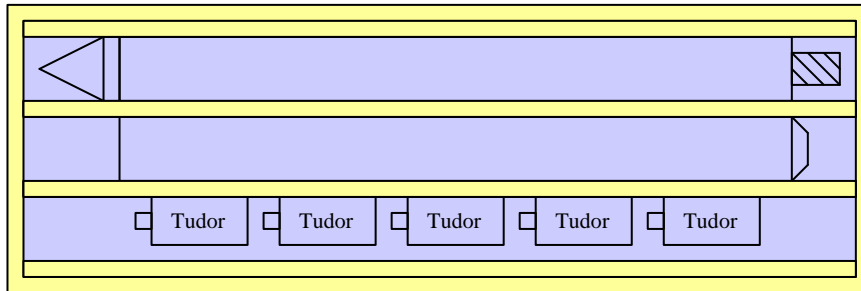

The ENVI MemoCone II Piezocone.

A complete setup for performance of CPT using the ENVI MemoCone II Piezocone consists of:

Datalogger C-Mon with software for CPT, in it's case.

Depth registration DRR.

Prepared points, O-rings, Grease and oil

5 pcs of ALKALINE batteries size C (LR14).

Users manual for CPT in memory mode.

Connect the main cable with the big plug at the back of the C-Mon or D-Mon, the cable with two loose ends at 12V / 24V DC and the cable with the Cannon plug to the depth transducer.

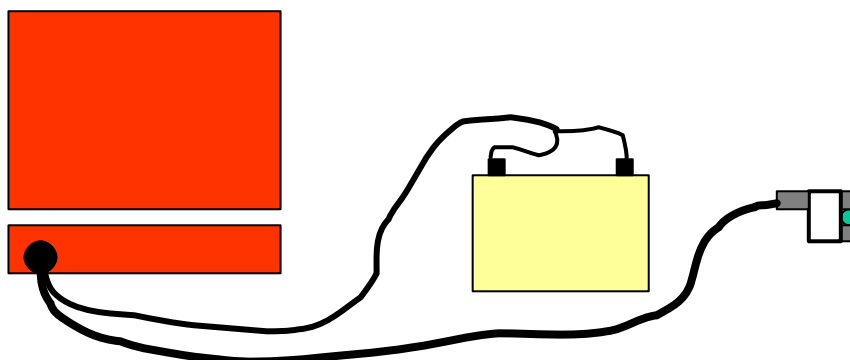

The D-Mon starts automatically when the power is connected.

Go to Sounding and press the centre button.

<i>D-Mon</i>		Tuesday 14 January 12:19								
<table border="1"><tr><td style="background-color: yellow;">Choose sounding method</td></tr><tr><td style="background-color: blue; color: yellow;">← Back</td></tr><tr><td>MWD Sounding</td></tr><tr><td>CPT (memory)</td></tr><tr><td>CPT (acoustic)</td></tr><tr><td>CPT (cable)</td></tr><tr><td> </td></tr><tr><td> </td></tr></table>		Choose sounding method	← Back	MWD Sounding	CPT (memory)	CPT (acoustic)	CPT (cable)			Main menu
		Choose sounding method								
		← Back								
		MWD Sounding								
		CPT (memory)								
		CPT (acoustic)								
		CPT (cable)								
Sounding										
System function										
Data transfer										
Settings										
Monitor setup										

Variations depending of the set up of methods in your D-Mon.

Preparation of the ENVI MemoCone II.

MemoCone
Conical filter point
Universal spanner
Grease
Hydraulic oil
Cable

Start by filling the conical filter point with grease. Make sure the filter point is entirely filled with grease and that there are no air bubbles in the point. Press grease into the filter point until you can see it coming out from the slot. Wipe away excessive grease.

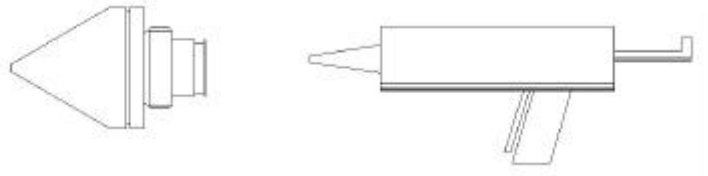

Fill the cavity in the lower part of the MemoCone with hydraulic oil and remove the air bubbles which are formed in the oil.



Then place the filter point into the MemoCone. Lean the point slightly to avoid air bubbles.

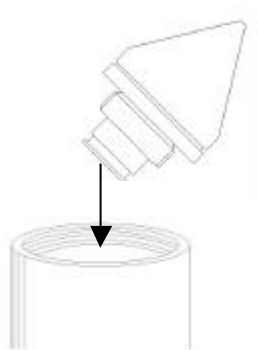

Place two O-rings behind the conical filter and one O-ring on the other end of the friction sleeve. Tighten the conical filter slightly using a universal spanner.

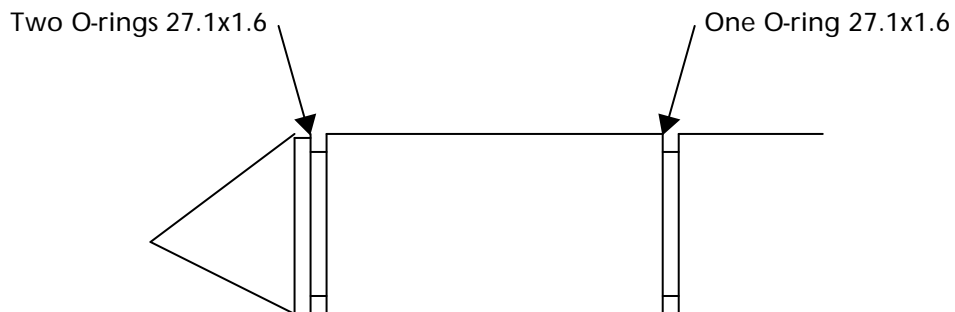

The MemoCone is now ready for sounding and can be stored "prepared" for several hours without affecting the measurement.

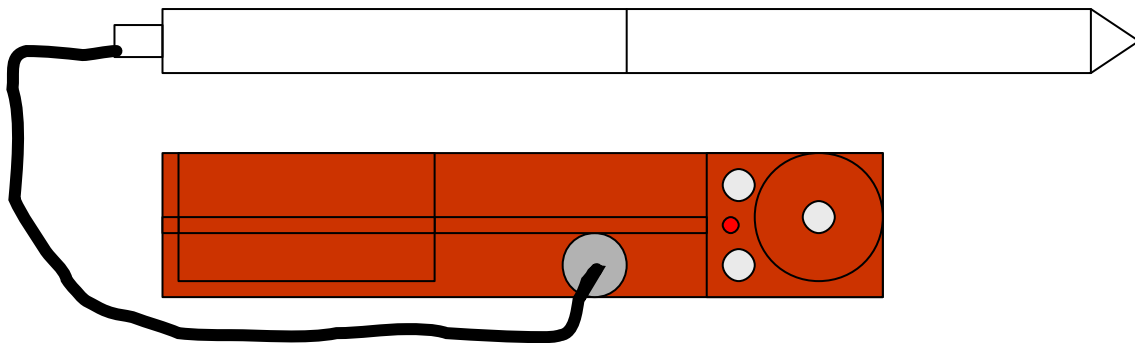

Connect the MemoCone II to the plug in the front of the C/D-Mon.

Go to CPT (memory) by rotating the wheel on the D-Mon and press centre button.

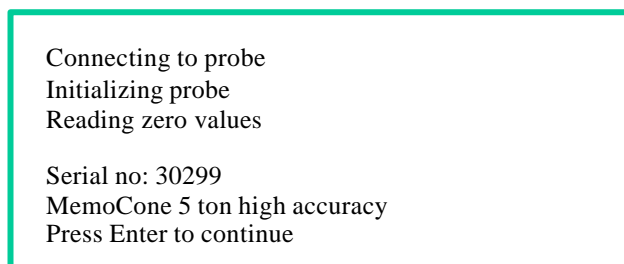

If readings of zero values are presented on the screen, it indicates that the values are outside the accepted.

DISCONNECT:

When this picture is shown on the screen, disconnect the cable from the MemoCone and put the **BATTERY PLUG** in the MemoCone instead of the cable.

Put five ALKALINE batteries, model Size C, 1,5V, in the battery tube, with the plus pole pointing **DOWNWARDS** when the cone is mounted and positioned to start the test. Don't use rechargeable batteries.

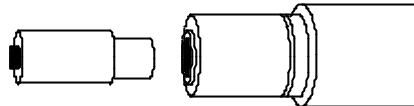

Screw the MemoCone and the battery tube together, but not completely. You should be able to watch the two lamps just inside the thread. A steady twinkling of the **green** lamp ensures that the MemoCone has started to take readings, If the **red** lamp is on, it means that the battery is poor and not good for a test. If the **green** light is twinkling **1 sec. ON – 1 sec. OFF**, screw together tight. The MemoCone is now ready for pushing.

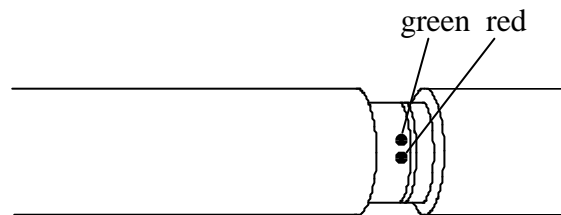

Press the centre button on the D-Mon.

If you start the test from the surface, just press the button.

If the hole is pre drilled through dry crust or fill, put in the pre drilled depth, by rotating the wheel and push the button.

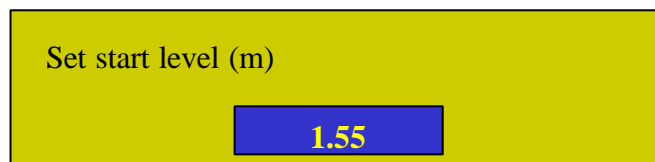

Enter project name	
← ESC	123456▼7890+-.@ ▼ ÅÄÖ
←	ABCDEFGHIJ▲KLMNOP▲QRSTUVWXYZ ←
ChiangiAirport	

Use the wheel as a joy stick and go between the letters, symbols and numbers. Confirm the letter with the centre button.

When the project name is written go to ←↵ and press the centre button. The selected project name will now be registered in the head of the data file.

For the next sounding this project name will be suggested as default.

If the project name shall be changed go to ← and erase the pre chosen name and type the new project name as described above.

Positioning of the sounding.

Select type of
No id
XYZ coordinates
Line, offset
Cancel sounding

If choosing:

No id: The software goes direct to reading zero values

Free id: Use the key board to print your bore hole number

XYZ coordinates: Use the key board to register first the X coordinate, than the Y coordinate and last the Z coordinate. For the changes use the ←

Centre line, offset: Use the key board to register centre line

Use the key board to register offset and Z coordinate

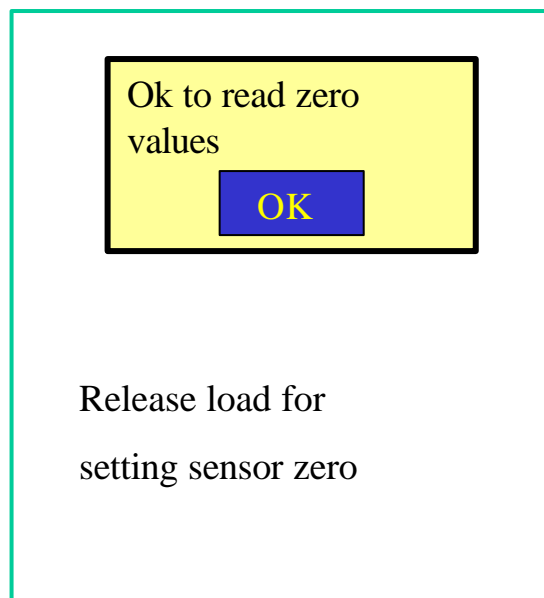

Push the centre button for OK.

The D-Mon puts the zero values in the data file as zero values before sounding.

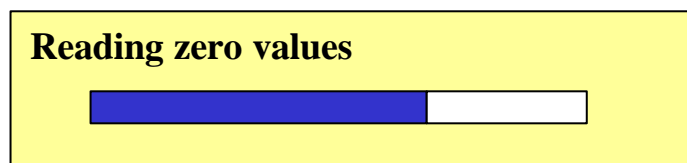

The screen on the D-Mon changes to this picture while sounding.

If the screen is presented with the Drilling symbol, you can change to graphs by choosing Switch to diagram.

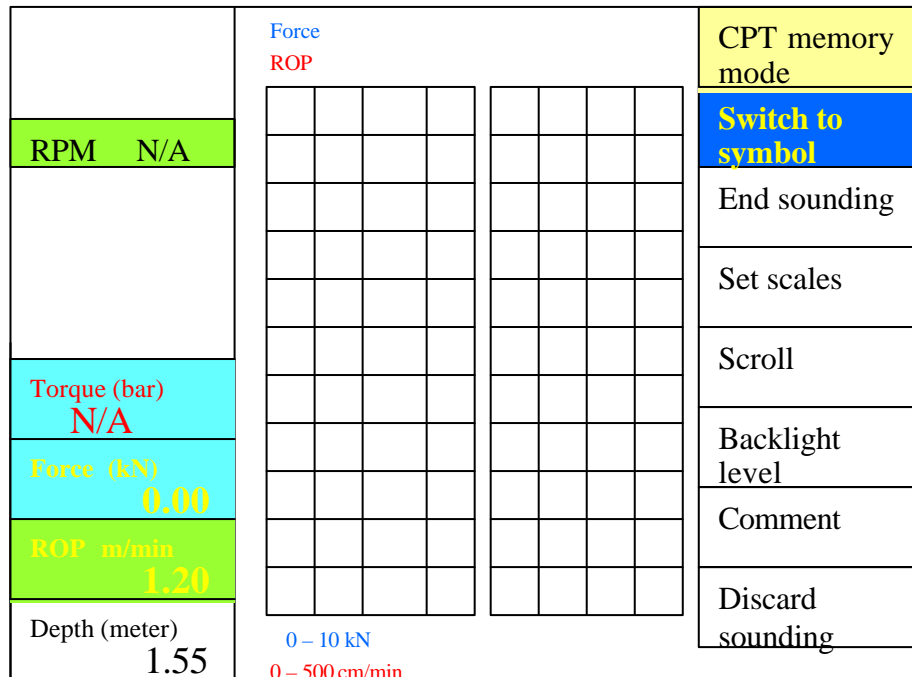

For CPT, as in this case, RPM and Torque is not used and marked N/A, not available. While pushing the MemoCone II, in memory mode, the graphs for depth, rate of penetration and applied feeding force are shown.

Place the MemoCone in the machine and start pushing.

OBSERVE: when the cone is starting to move, **PUSH** the **PLUS BUTTON**. The red light goes out and the registration starts. The **PLUS BUTTON** must be pushed at every rod shift, to make the registration collected in the D-Mon.

In order to protect the MemoCone from being overloaded, please do not use total load higher than indicated in the table below:

Depth	10 ton cone	5 ton cone
0-10m	10 tons	5 tons
10-20m	13 tons	8 tons
20-30m	18 tons	11 tons
>30m	20 tons	16 tons

Downloading the data from ENVI MemoCone II

After retraction of the cone, take the cone from the machine and unscrew the battery tube. Connect the cone as described on page 14.

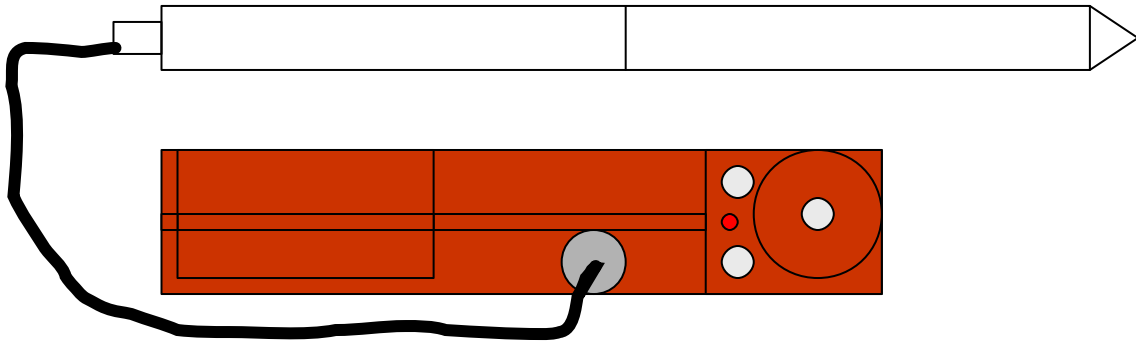

Select "End sounding" on the screen by rotating the wheel and press the centre button.

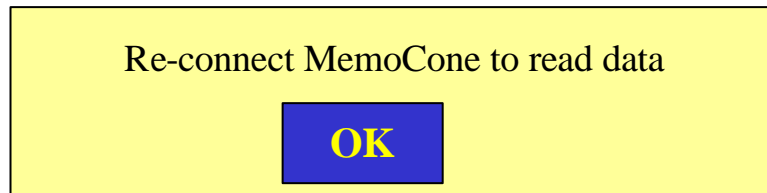

Choose OK by pressing the centre button.

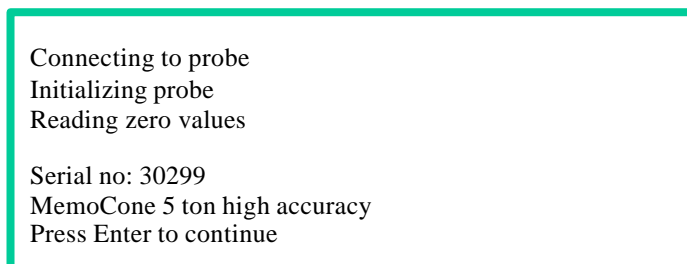

If readings of zero values are presented on the screen, it indicates that the values are outside the accepted.

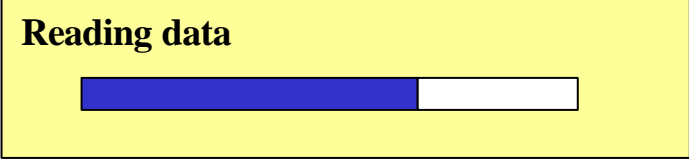

All the stored data is now transferred from the MemoCone to the D-Mon and is presented on the screen.

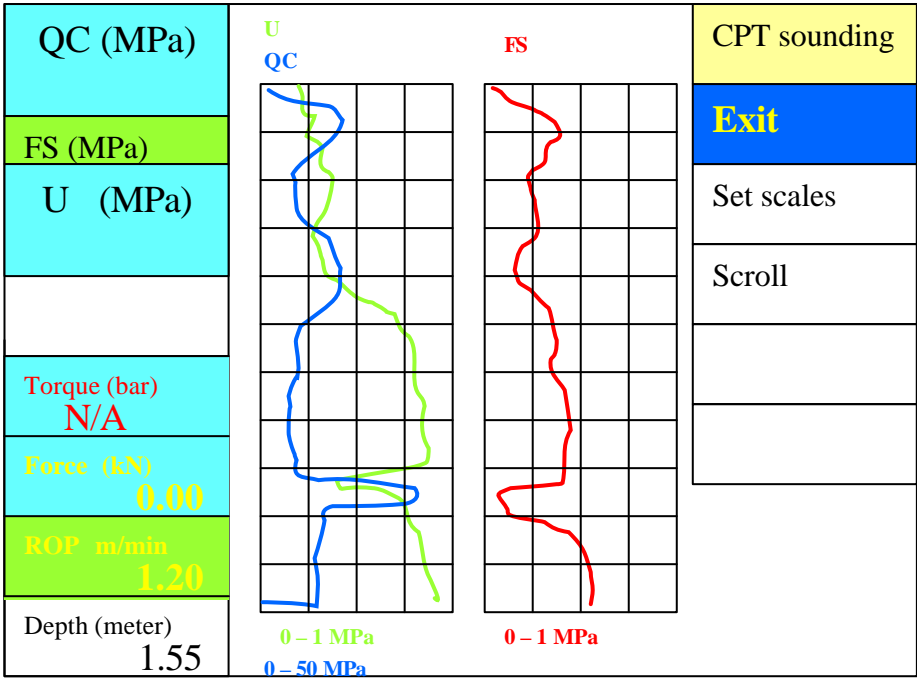

DISSIPATION TEST
(Memory operation)

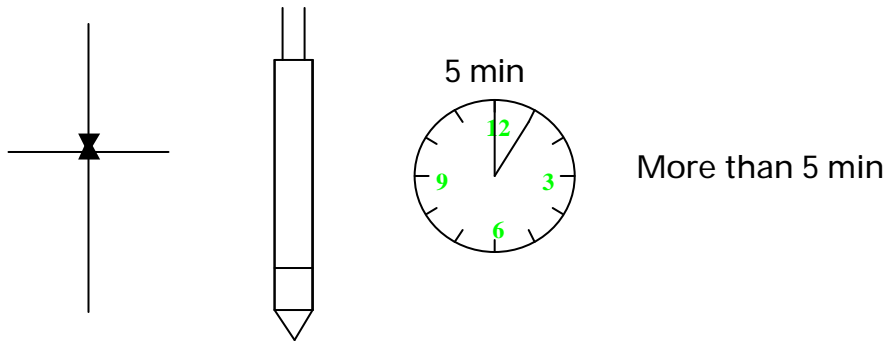

STOP PENETRATION

WAIT > 5 MINUTES

OBSERVE The maximum operation time for the Memocone II is 8 hours.

To stop the dissipation test, just continue the penetration. Of course you can make more dissipation tests further down. If you want to terminate the penetration, you must stop the dissipation test first.

This is done by **continuing the penetration a few centimetres.**

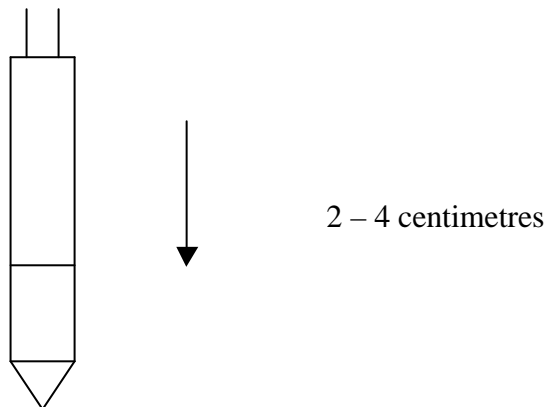

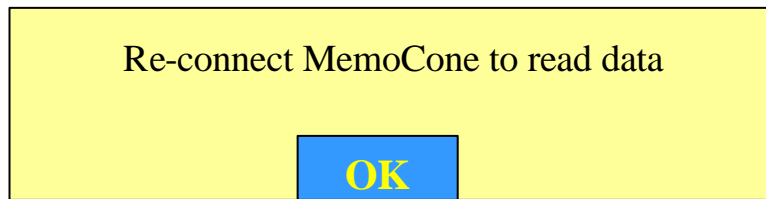

The MemoCone downloads the zero values, all the CPT data, presents it as graphs.

After this the dissipation test (s) is downloaded.

Put in the project name and type of id.

The test level/s is/are written on the screen.

Test level 32.00 (meter)	Time	U_t	Dissipation
	01:50	0.315	Exit
	01:25	0.325	Scroll
	01:06	0.335	
	00:29	0.361	
	00:22	0.349	
	00:16	0.394	
	00:11	0.431	
	00:08	0.365	
	00:05	0.333	

Download the data in the normal way to a floppy disk. See next page.

Take the floppy and download the data to your presentation soft ware in the office computer and make the graph for the dissipation test.

As an example below from SGI, EDISON.

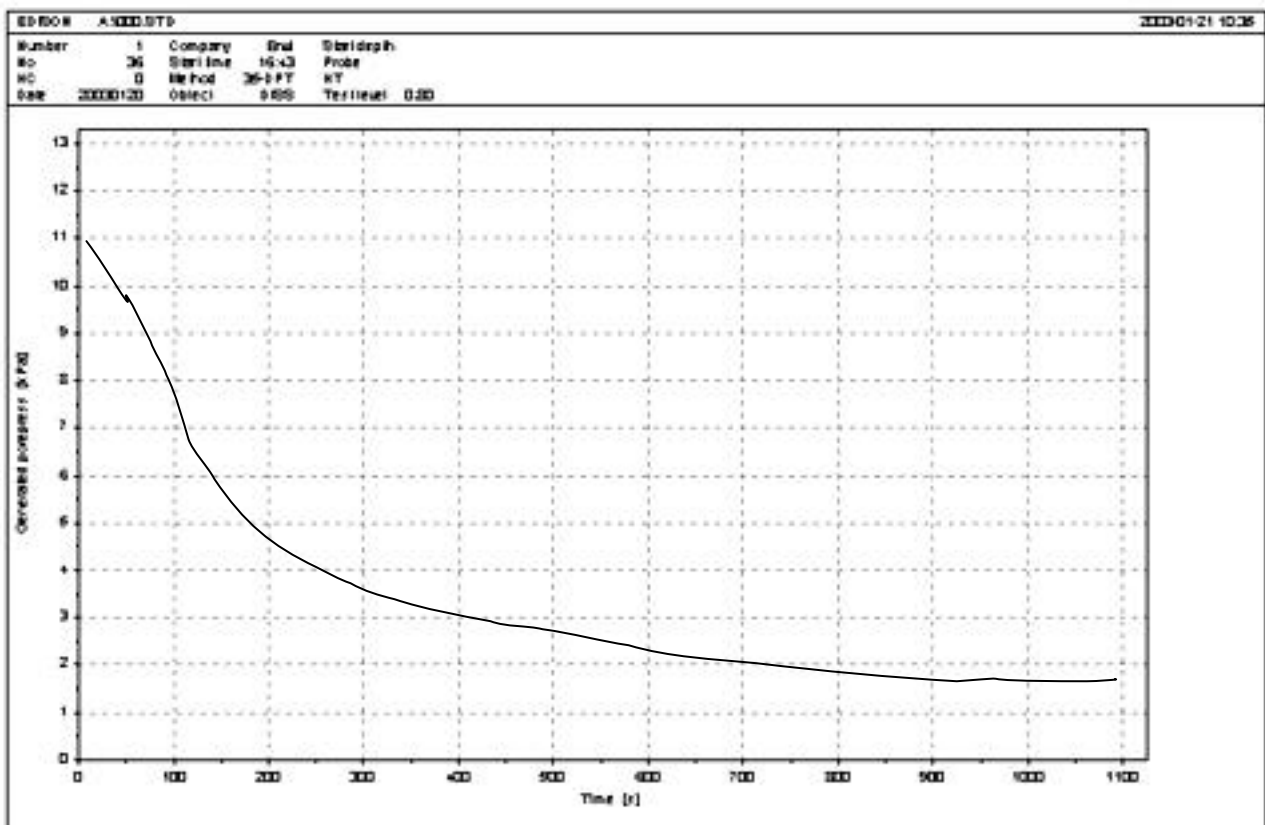

Downloading data from the D-Mon to floppy.

Choose Data transfer from the main menu

Choose down loading method
← Cancel
Not downloaded
From a project
From a date
From internal id

Choose the method for downloading and press the centre button.

The hatch is opening automatically. Put in a floppy disk.

From Not downloaded select the required data format:

Select data format
STD format
Text format

STD format is a standardised format used within the geotechnical and geological branches in Scandinavia.

Text format is the international ASCII format for i.e. EXCEL.

MAINTENANCE of the MEMOCONE

After every test:

- Displace the friction sleeve about 20 mm downwards by gentle rotating and pulling.
- Use a toothbrush and clean up the upper and lower joints.
- Smear with grease.
- Push and rotate the Friction sleeve gently back into position.
- Put the O – ring back into position

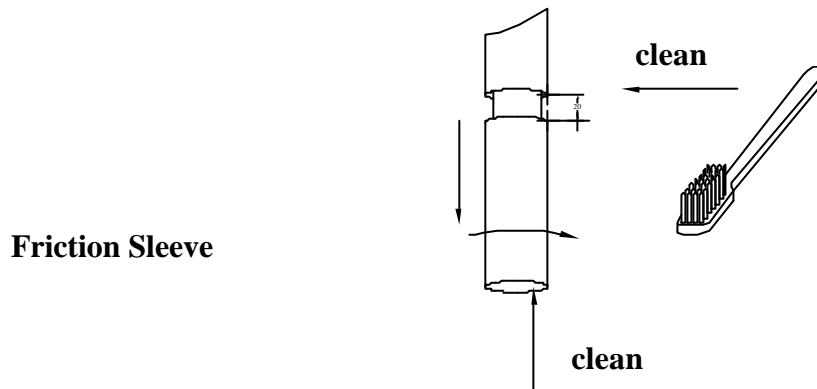

After the completed project:

• Remove the friction sleeve completely, clean and grease. Remove the ring from the conical filters and clean them with compressed air.

Smear the complete probe and battery tube (steel tubes) with oil before storage. Grease all O-rings.

Users manual for CPT in cable mode.

PREPARATIONS:

MemoCone
Conical filter point
Universal spanner
Grease
Hydraulic oil
Cable

Start by filling the conical filter point with grease. Make sure the filter point is entirely filled with grease and that there are no air bubbles in the point.

Press grease into the filter point until you can see it coming out from the slot on the filter point. Wipe away excessive grease.

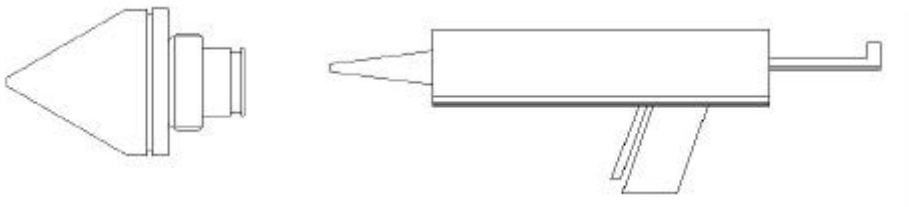

Fill the cavity in the lower part of the MemoCone with hydraulic oil and remove the air bubbles which are formed in the oil.



Then place the filter point into the MemoCone. Lean the point slightly to avoid air bubbles.

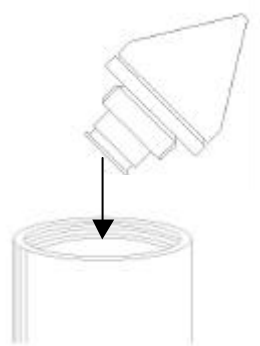

Place two O-rings behind the conical filter and one O-ring on the other end of the friction sleeve. Tighten the conical filter slightly using a universal spanner.



The MemoCone is now ready for sounding and can be stored "prepared" for several hours without affecting the measurement.

CABLE CONNECTIONS:

1. Connect the **CABLE** to the terminal **B**
2. Tighten the **GLAND A**
3. Fill with **OIL** in the **BRASS TUBE C** up to level **D**
4. Put on the brass tube and lock the bayonet
5. Screw on the **STEEL TUBE E**
6. Connect the MemoCone and rotate 6 turns counter clockwise
7. Screw together

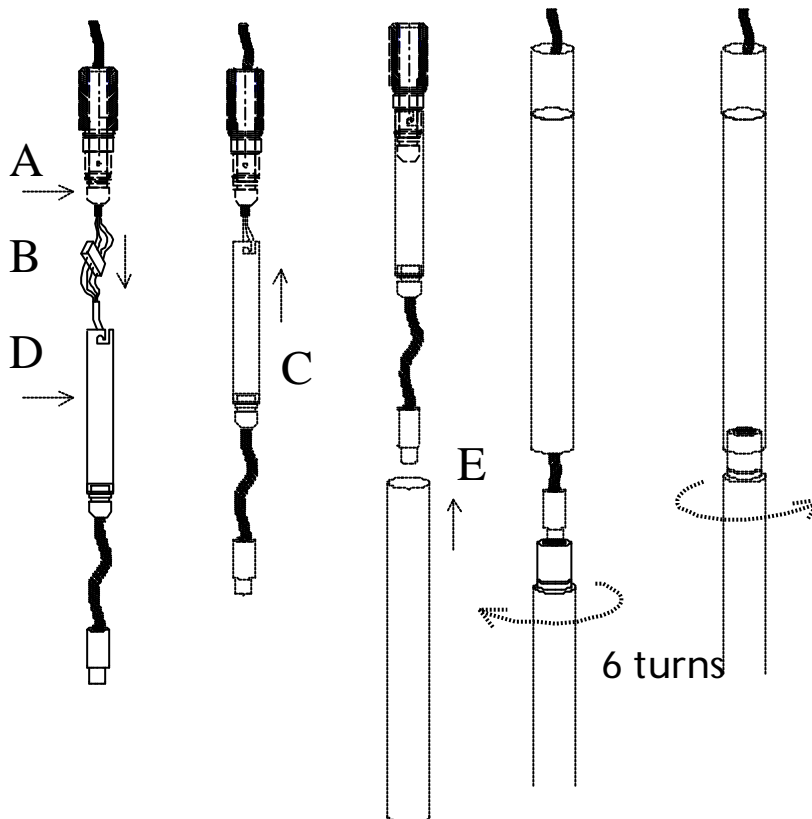

Connect the cable to the plug in the front of the D-Mon.

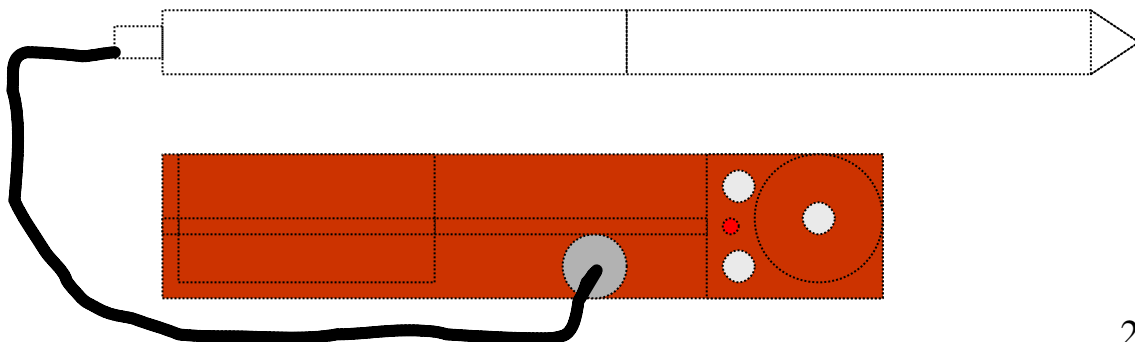

<i>D-Mon</i>		Tuesday 14 January 12:19
<div style="border: 1px solid black; padding: 5px; margin: 10px auto; width: 80%;"> <div style="background-color: yellow; padding: 2px; text-align: center;">Choose sounding method</div> <div style="padding: 2px; text-align: center;">← Back</div> <div style="padding: 2px; text-align: center;">MWD Sounding</div> <div style="padding: 2px; text-align: center;">CPT (memory)</div> <div style="background-color: blue; color: yellow; padding: 2px; text-align: center;">CPT (cable)</div> <div style="padding: 2px; text-align: center;">CPT (acoustic)</div> <div style="padding: 2px; text-align: center;"> </div> </div>		Main menu
		Sounding
		System function
		Data transfer
		Settings
		Monitor setup

Variations depending of the set up of methods in your D-Mon.

Go to CPT (cable) and push the centre button.

Connecting to probe
 Initializing probe
 Reading zero values

Serial no: 30299
 MemoCone 5 ton high accuracy
 Press Enter to continue

If readings of zero values are presented on the screen, it indicates that the values are outside the accepted.

Screw the MemoCone and the cable tube together, but not completely. You should be able to watch the two lamps just inside the thread.

A steady twinkling of the **green** lamp ensures that the MemoCone has started to take readings.

When the **green** light is twinkling **1 sec. ON – 1 sec. OFF**, screw together tight, The MemoCone is now ready for pushing.

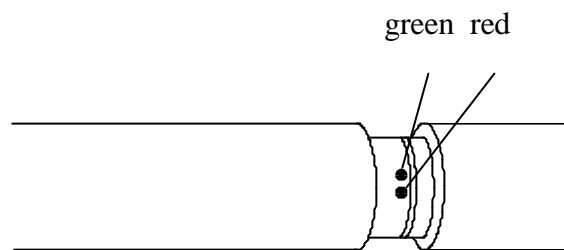

Press the centre button on the D-Mon.

If you start the test from the surface just press the button.

If the hole is pre drilled through dry crust or fill put in the pre drilled depth by rotating the wheel and push the button.

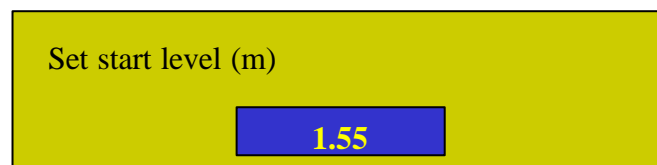

Enter project name	
← [ESC] 12345 7890+-.@ ▼ ÅÄÖ	↵
← ABCDEFG▲HIJKLMNQP▲QRSTUVWXYZ	↵
ChiangiAirport	

Use the wheel as a joy stick and go between the letters, symbols and numbers. Confirm the letter with the centre button.

When the project name is written go to ←↵ and press the centre button. The selected project name will now be registered in the head of the data file.

For the next sounding this project name will be suggested as default.

If the project name shall be changed go to ← and erase the pre chosen name and type the new project name as described above.

Positioning of the sounding.

Select type of
No id
Free id
XYZ coordinates
Line, offset
Cancel sounding

If choosing:

No id: The software goes direct to reading zero values

Free id: Use the key board to print your bore hole number

XYZ coordinates: Use the key board to register first the X coordinate, than the Y coordinate and last the Z coordinate. For the changes use the ←

Centre line, offset: Use the key board to register centre line

Use the key board to register offset and Z coordinate

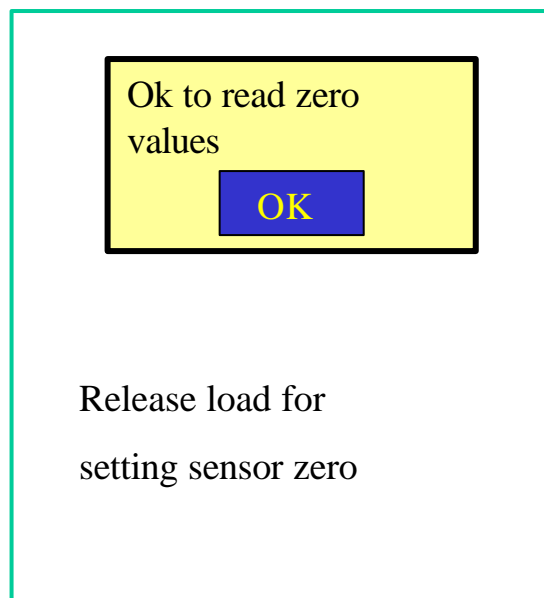

Push the centre button for OK.

The D-Mon puts the zero values in the data file as zero values before sounding.

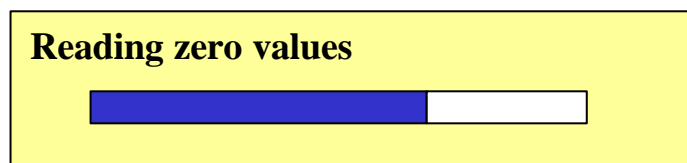

The screen on the D-Mon changes to this picture while sounding.

If the screen is presented with the Drilling symbol, you can change to graphs by choosing Switch to diagram.

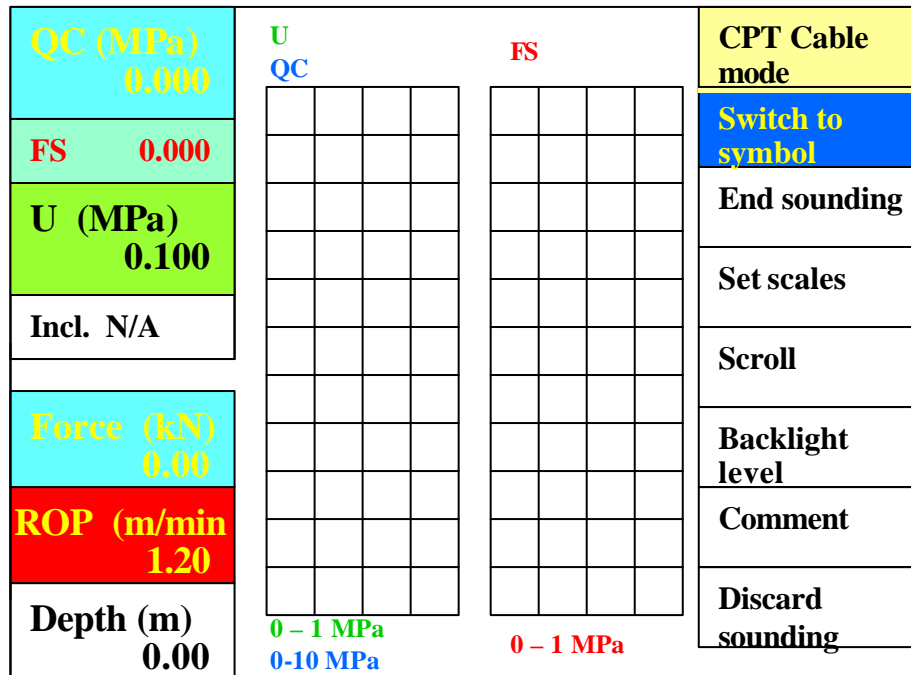

For CPT, as in this case, no inclinometer is mounted, marked N/A, not available.

While pushing the MemoCone II, in cable mode, the graphs for depth, point resistance, local friction and generated pore pressure are shown in real time.

In order to protect the MemoCone from being overloaded, please do not use total load higher than indicated in the table below:

Depth	10 ton cone	5 ton cone
0-10m	10 tons	5 tons
10-20m	13 tons	8 tons
20-30m	18 tons	11 tons
>30m	20 tons	16 tons

Starting the penetration.

Place the MemoCone in the machine and start pushing.

OBSERVE: when the cone is starting to move, **PUSH** the **PLUS BUTTON**. The red light goes out and the registration starts. The **PLUS BUTTON** must be pushed at every rod shift, to make the registration collected in the D-Mon. Not with C-Mon and depth gauge wheel on the rod

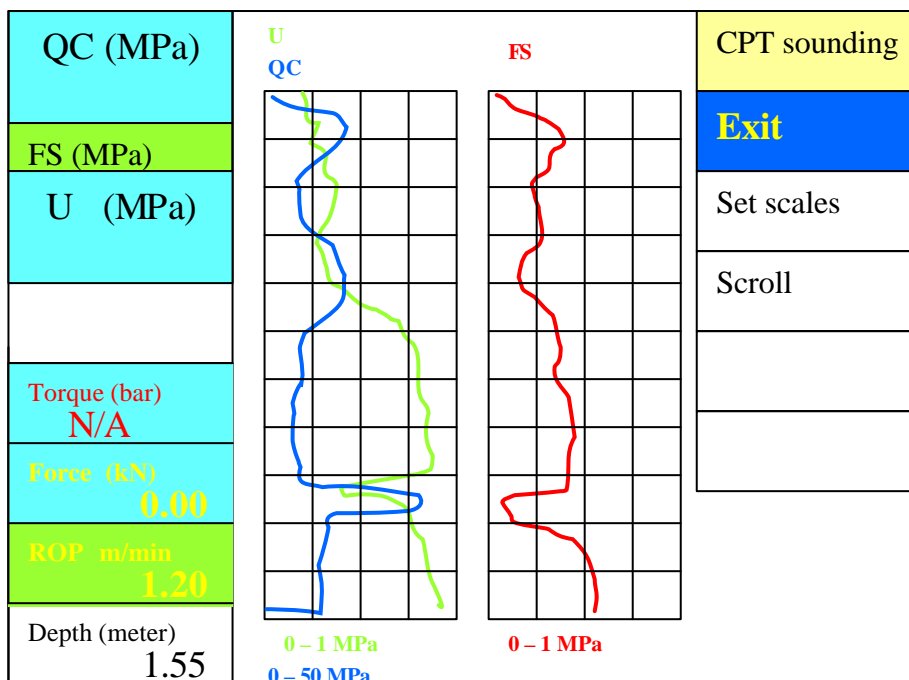

Stop the CPT test.

Rotate the wheel to End sounding and push the button.

The D-Mon reads the zero values after the test and store all the data in the hard disk drive.

Downloading data from the D-Mon to floppy.

Choose Data transfer from the main menu

Choose down loading method
← Cancel
Not downloaded
From a project
From a date
From internal id

Choose the method for downloading and press the centre button.

The hatch is opening automatically. Put in a floppy disk.

From Not downloaded select the required data format:

Select data format
STD format
Text format

STD format is a standardised format used within the geotechnical and geological branch in Scandinavia.

Text format is the international ASCII format for i.e. EXCEL.

MAINTENANCE of the MEMOCONE

After every test:

- Displace the friction sleeve about 20 mm downwards by gentle rotating and pulling.
- Use a toothbrush and clean up the upper and lower joints.
- Smear with grease.
- Push and rotate the Friction sleeve gently back into position.
- Put the O – ring back into position

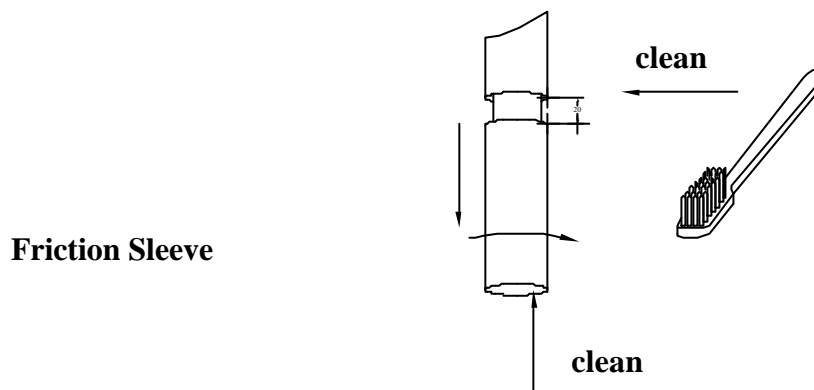

After the completed project:

• Remove the friction sleeve completely, clean and grease. Remove the ring from the conical filters and clean them with compressed air.

Smear the complete probe and battery tube (steel tubes) with oil before storage. Grease all O-rings.

CPT with acoustic data transmission.

MemoCone III

For real time acquisition you can besides the cable also use the acoustic option.

It consists of a sound transmitter, instead of the battery tube, a sound receiver and a microphone.

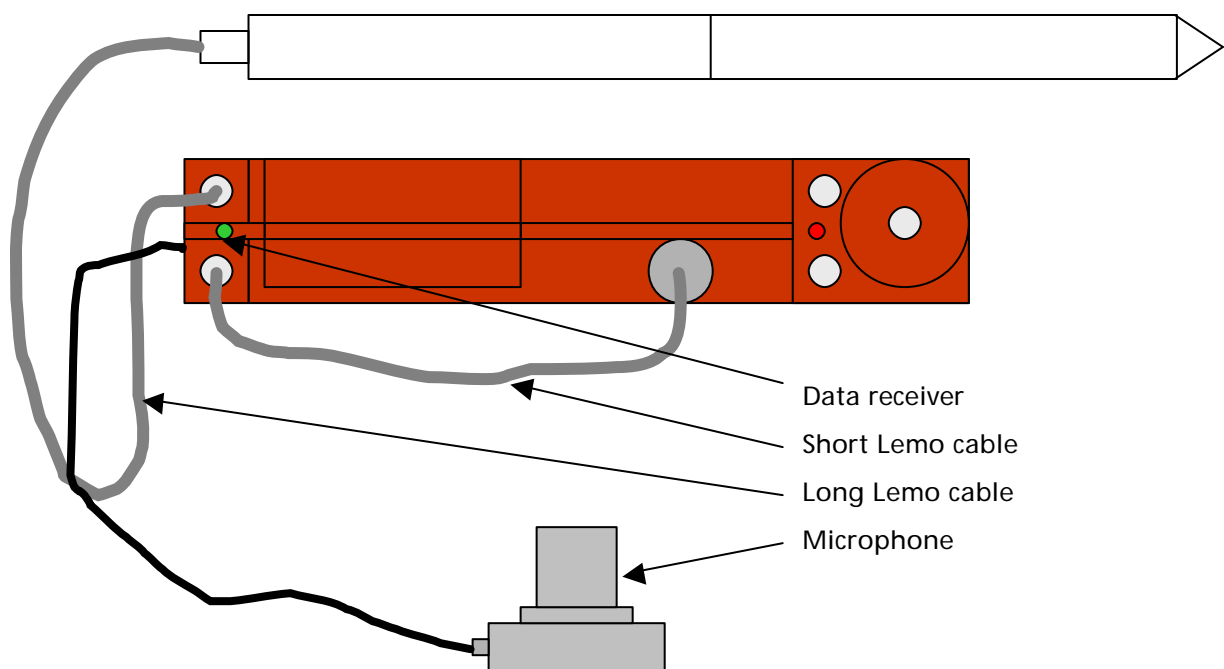

Fasten the data receiver on the C/D Mon and connect the short Lemo-Lemo cable between the MemoCone plug.

Fasten the microphone cable between the microphone and the back of the receiver.

Connect the MemoCone III between the upper receiver plug and the MemoCone III with the longer Lemo-Lemo cable.

Fasten the microphone on the push head and push on top of the rods with the microphone.

Proceed in the same way as described for MemoCone II and cable.

The DATA file.

There are two major formats for the drilling parameter data file:

1. STD type file for evaluation programs: EDISON and CONRAD (CPT):

```
$
HA=1,HB=80,HC=ENVI-0,HO=0.03,HD=19930902,HM=60,HJ=peabs4,HF=PEAB
#
D=0.03,A=0,B=245.5I=0,G=0,R=67,P=0.3438
D=0.04,A=0,B=255.83,I=0,J=0.73242,G=0,R=67,P=0
D=0.07,A=0,B=240.67,I=0,J=0.48828,G=0,R=67,P=1.5625
D=0.08,A=0,B=219.17,I=0,J=0.24414,G=0,R=67,P=1.5625
D=0.1,A=0,B=144.33,I=0,J=0,G=0,R=67,P=1.5625
D=0.12,A=0,B=39.5,I=0,J=0.73242,G=0,R=67,P=0.78125
D=0.14,A=6.748,B=0.5,I=0.84529,J=2.4414,G=45.41,R=67,P=6.9531
D=0.16,A=7.8455,B=72.5,I=0.85027,J=2.4414,G=52.49,R=0,P=8.0273
D=0.18,A=5.6504,B=95.833,I=0.84529,J=2.1973,G=59.326,R=0,P=7.6758
D=0.2,A=6.8293,B=133.33,I=0.83038,J=2.4414,G=66.162,R=70,P=6.9531
```

2 TXT type of file (for ECXEL etc.):

```
$
HA=1,HB=1,HC=ENVI-79,HO=19970429,HI=10:20,HM=60
#
DEPTH BITLOAD ROP F PRESS FLOW RPM TORQUE CODE TEXT
0.02 20.081 36.5 0.0198 0.0011 0 7.7615
0.04 20.081 28.5 0.0198 0.0011 0 7.7615
0.06 20.122 32.4 0.0198 0.0011 0 7.7615
0.08 20.122 29.0 2.0336 0.0011 0 7.7615
0.10 20.081 29.7 4.8624 7.1782 13.3 7.7615
0.12 20.122 172.83 7.4465 13.772 44.8 7.7615
0.14 18.855 170.5 5.9786 15.99 67.8 7.7615
0.16 18.033 167.88 6.1009 17.371 85.5 8.2111
0.18 16.432 169.0 6.1009 19 88.3 11.691
0.20 16.011 171.446.1009 19.856 88.9 13.685
```

LEGEND:

Heading

HA = No of heading
HB = Serial No of registration
HC = Serial No of data collector
HD = Date
HI = Start time for registration
HM = Method code
HF = Company name
HJ = Name of object
HL = Section
HH = Deflection to the right of section centre
HV = Deflection to the left of section centre
HK = No of registration given in the field
HT = Text
HN = Number of probe

Data:

D = depth in metres
K = 2 digit codes
T = Text string
A = Bit load in kN
B = Rate of penetration (ROP) in mm/s
F = Local friction (CPT)
Q = Point resistance (CPT)
U = Generated pore pressure (CPT)
J = Flow in to the borehole of flushing medium in l/min
G = Flow out of the borehole of flushing medium in l/min
I = Pressure of flushing medium in MPa
P = Rotation motor pressure (torque)
R = Rotation speed (rpm)
S = Number of blows per 0.2 meter
AZ = Hydraulic pressure on drifter/hammer

Monitoring While Drilling (MWD).

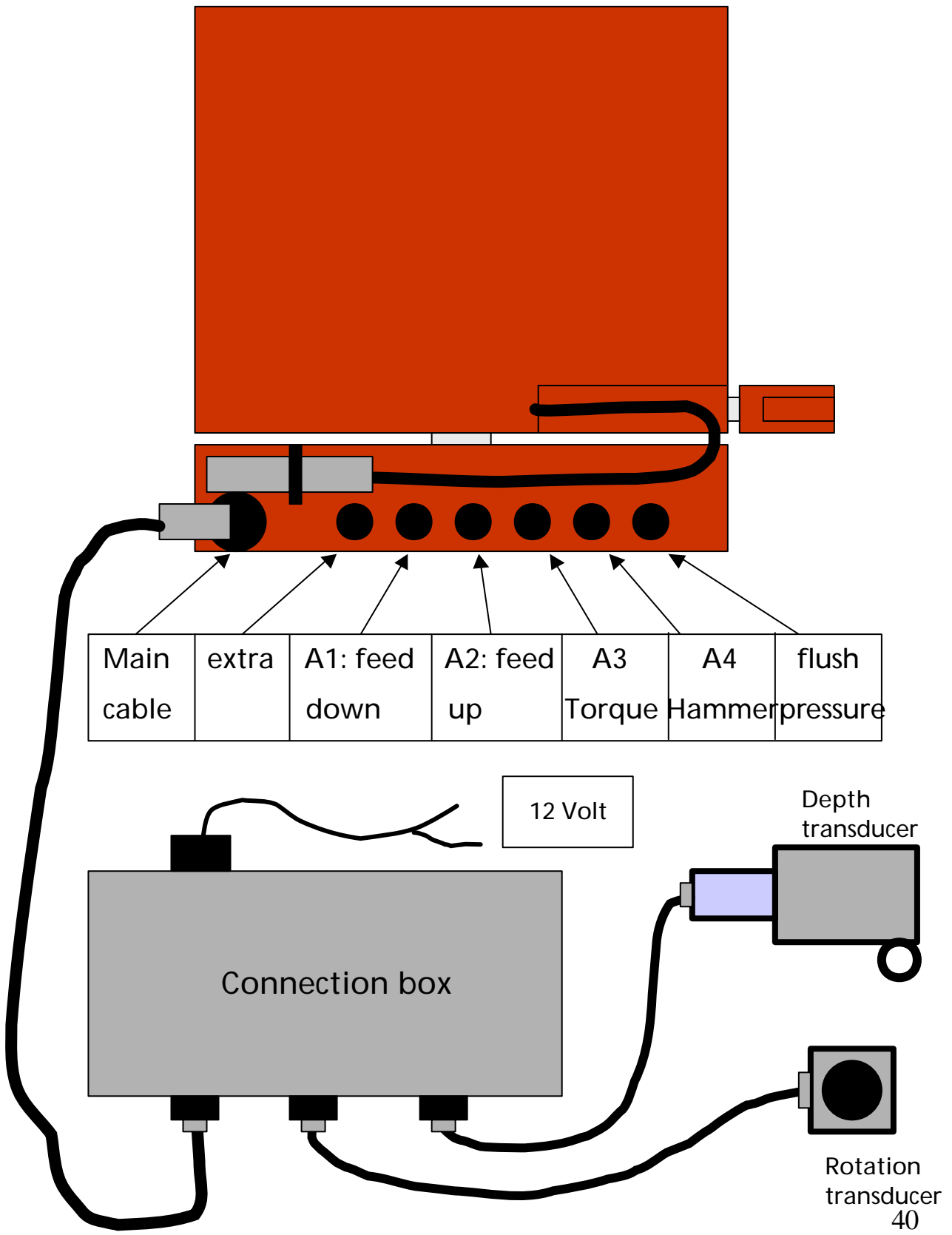

Connect the D-Mon, connection box, depth transducer and the rotation transducer according to the drawing.

When the cable for the power is connected, the D-Mon starts automatically. Variations depending of the set up of methods in your D-Mon.

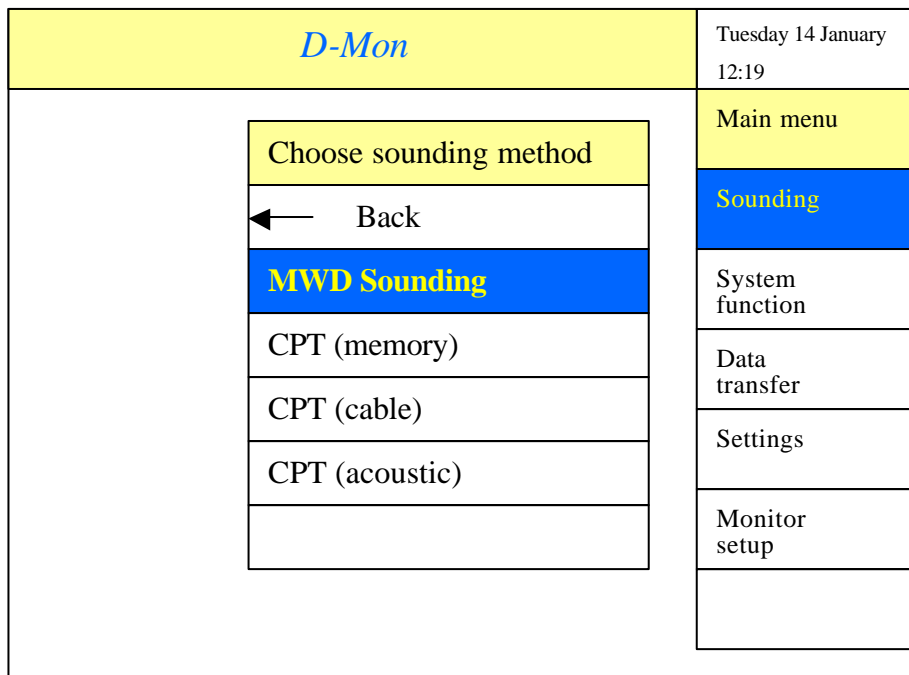

Choose sounding with the wheel and confirm by pressing the centre button. Choose MWD Sounding with the wheel and confirm with the centre button.

If you have pre drilled change 0.00 with the wheel until the pre drilled depth and press the centre button.

Use the key board on the screen for registration of the Project name.

The ← button erases the pre chosen name.

The ↵ button takes you to the next picture.

Select type of positioning:

No id
Free id; your own borehole number
XYZ coordinates
Centre line, offset

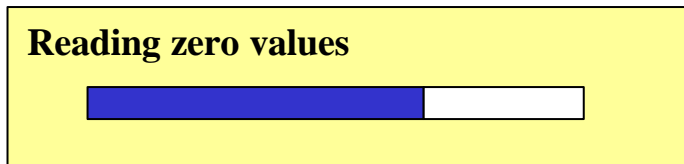
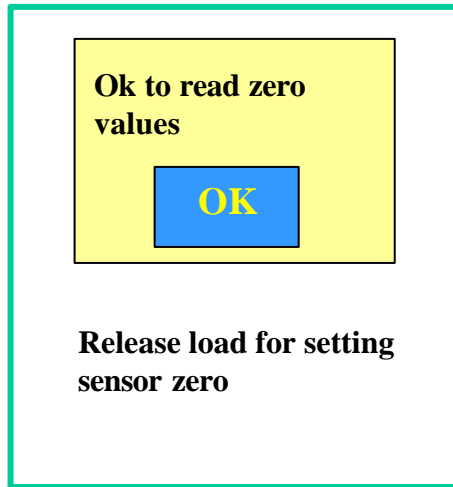

The values from all installed sensors on the rig are checked, read and stored in the data file as zero values.

Flush-P (bar) 0		MWD sounding
RPM 0		Switch to Diagram
Flow (l/min) 0		End sounding
Torque (bar) 0		Backlight level
Force (kN) 00.0		Comment
ROP (m/min) 0.00		Discard sounding
Depth (meter) 0.00		

Rate of Penetration (ROP) Bit load Torque RPM Rod clamp

Start the drilling by pushing the **PLUS BUTTON**.

On the numerical fields to the left are shown:

Flushing pressure in bar.

RPM in revolutions per minute.

Flow volume of drilling fluid.

Hydraulic pressure from rotation motor in bar.

Bit load in kilo Newton

Rate Of Penetration (ROP) in meter per minute



Depth in meters.

All parameters are presented in different colours. If you have programmed the D-Mon with minimum and maximum values valid for your type of drill rig the **COLOURS WILL CHANGE TO RED** if the maximum values are exceeded or if the minimum values are being below.

In the centre of the screen the "drilling symbol" presents all data as graphs with different colours in real time.

With just a quick glimpse you will see the status of your drilling.

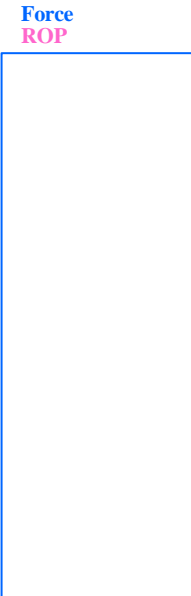
If you need the history from the drilling, all the way from surface, go to Switch to diagram. On the centre graphs, you will have the curves of Bit load, ROP, Flushing pressure and the Torque.

Flush-P (bar) 0	<div style="display: flex; justify-content: space-around;"> <div style="text-align: center;"> <p>Force ROP</p>  <p>0 – 10kN 0 – 500 cm/se</p> </div> <div style="text-align: center;"> <p>Flush pressure Torque</p>  <p>0 – 50 bar 0 – 100 bar</p> </div> </div>	MWD sounding
RPM 0		Switch to symbol
Flow (l/min) 0		End sounding
Torque (bar) 0		Set scales
Force (kN) 00.0		Scroll
ROP (m/min) 0.00		Backlight level
Depth (meter) 0.00		

This is an example of a MWD drilling.

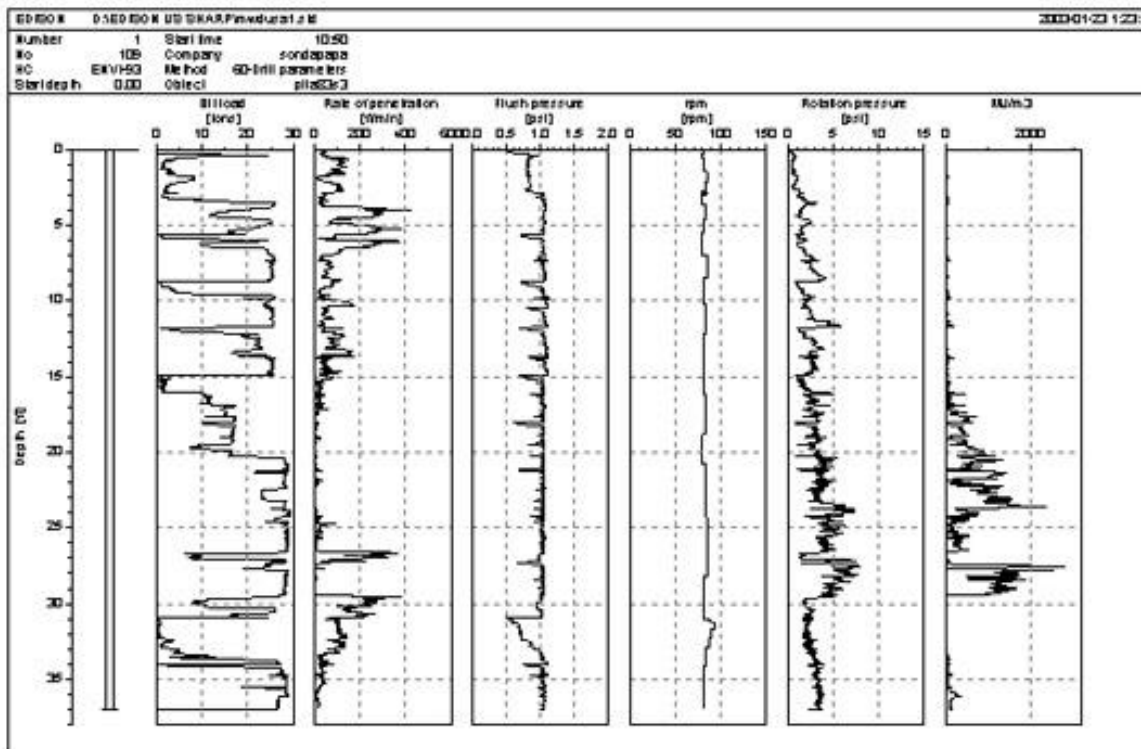

At the Volcano Vesuvius in Italy, a couple of years ago, some land slides destroyed one of the slopes.

Today a rail road is going to be built and one of the main problems was to determine if there were any cavities produced by the land slides.

From the graphs we can see that the drilling conditions varied a lot. It is very difficult to evaluate the results. By adding the formula for specific energy using the drilling parameters you get a lot more information and understanding of the soil layers from the surface down to 37 meters

Specific Energy:
$$E = \frac{E}{A} + \frac{2\pi NT}{AV}$$

- 0 – 16 m: Soft material
- 16 – 26 m: Harder materials with boulders
- 26 – 27 m: **Cavity**, energy needed almost zero
- 27 – 29 m: Hard soil
- 29 – 33 m: **Cavity**, energy needed almost zero
- 33 – 37 m: Soft material.

Jet Grouting

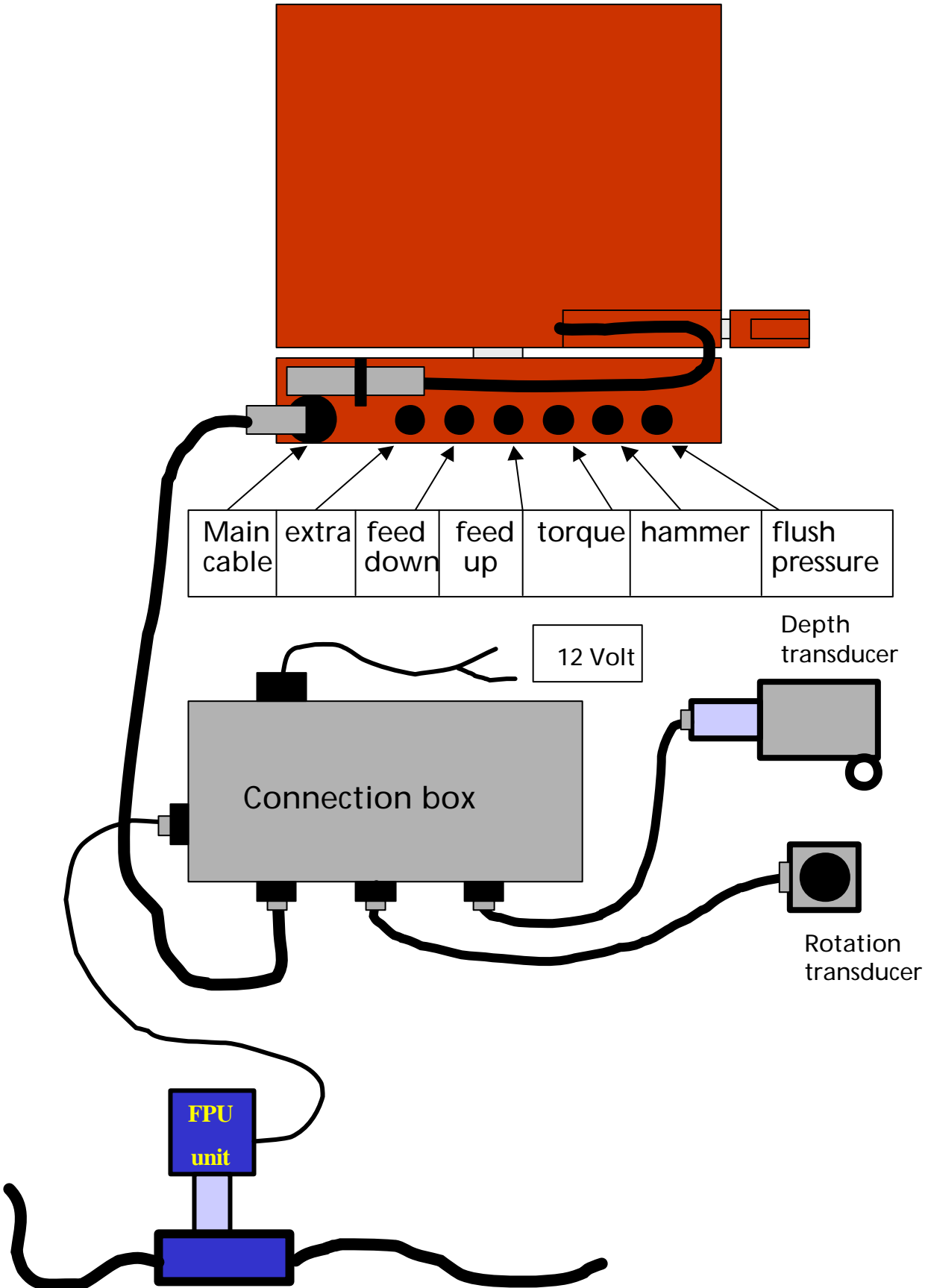

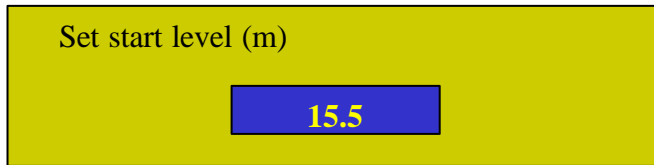

When performing a registration of Jet Grouting observe that measuring of depth starts from down and goes up.

Enter the Project name by using the key board on the screen and the wheel.

← erases the pre chosen name.

← leaves the key board for the next picture.

Select the type of positioning.

	RPM ROP	Cement pressure Flow rate	Jet Grouting
RPM 0			Switch to symbol
Flow (l/min) 0			End sounding
Pres C (MPa) 0			Set scales
X:-50 Y:-50			Scroll
ROP (m/min) 0.00			Backlight level
Depth (meter) 15.50			
	0 – 100 RPM 0 – 500 cm/min	0 – 50 MPa 0 – 100 l/min	

When the pile is completed go to End sounding and press the centre button.

Down load of data: Look at page 35.