

PC-Mon®

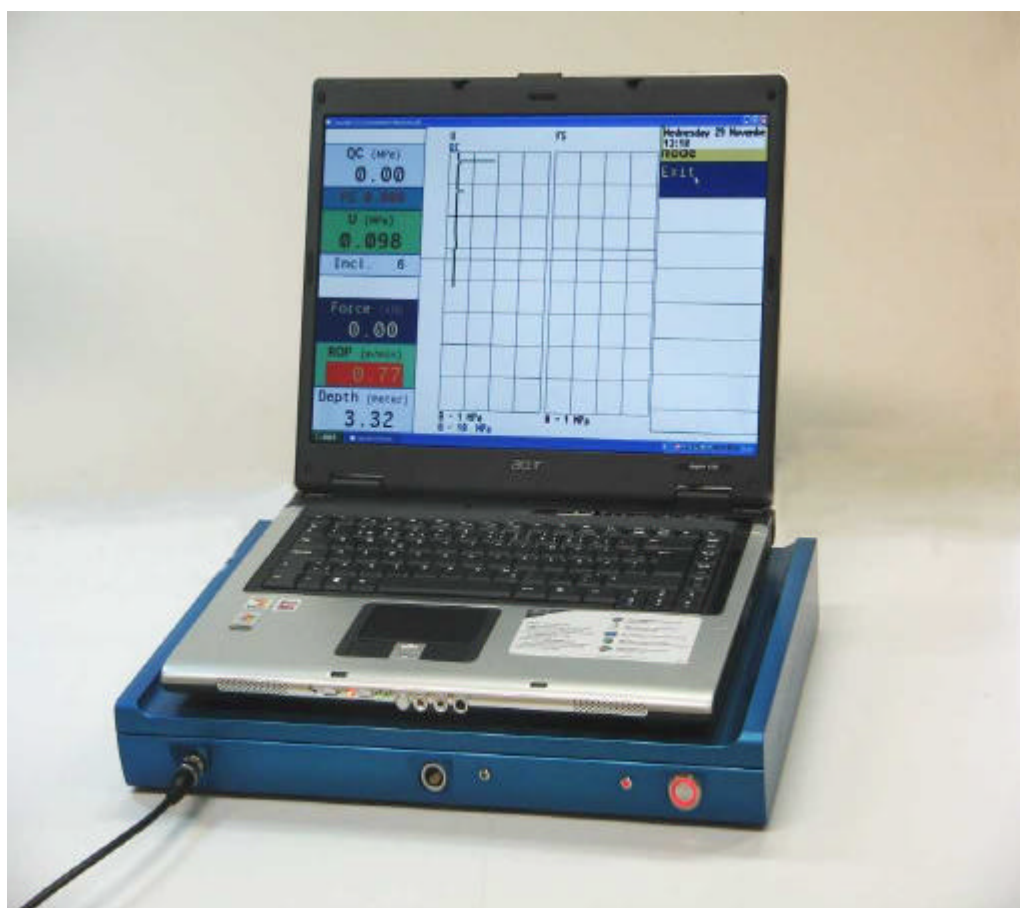

PC-mon™
Data logger for
CPTU
Memocone type II and III

Environmental Mechanics AB
Mr: Kjell Elmgren
Kungegardsgatan 7

S-441 57 ALINGSAS
Sweden

Tel: +46 322 67 03 30
Fax: +46 322 63 67 56
E-Mail: info@envi.se
URL: www.envi.se

General Description.

The latest generation of data loggers for registration of CPTU.

PC-Mon.

PC-mon stands for PC Interface monitor. This unit is the link between the CPTU probes Memocone type II and type III and a portable PC.

NOTE: The portable PC is NOT INCLUDED in the delivery.

The software PC-mon v 1.0 or later has to be installed in the portable PC.

The handling of the PC-Mon is totally menu operated. All possibilities at upstart, operation, registration of data and collection of data is clearly described on the screen. All input is done by the keyboard and arrow-up and arrow-down buttons.

Technical specification:

Size: 420 x 300 x 55 mm

Weight: 5 Kg

Cabinet: Machined Aluminium

Power requirement: 12 V DC (Car battery)

Consumption: 1 A , FUSE : 6 A

Inputs: 12 Volts power, CPT Probe, Depth transducer encoder, Microphone, Pressure sensor (Bosch type)

Outputs: 12 Volts for PC, USB port

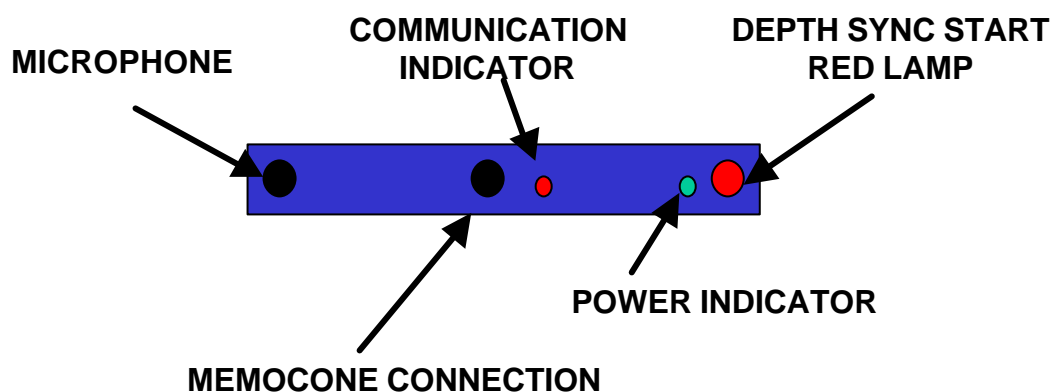

General.

The PC-Mon is fully menu oriented. All information is presented on the screen. Go through the different options with the **ARROW-UP/DOWN** and make the choice by pressing **ENTER**.

The **DEPTH SYNC START BUTTON** on the PC-mon starts the logging and retracting the rods stops the logging.

<i>PC-Mon</i>	Tuesday 14 January 12:19
	Main menu
	Sounding
	System functions
	Data transfer
	Settings
	Monitor setup

Connect the 12 Volt Power Cable and the PC-Mon and start up the PC-mon software in the PC. The first picture on the screen is the Main menu. Apart from product name and Logo, you find five pop up menus.

Sounding	Here you change between the different sounding methods programmed
System functions	Here you will find all directories
Data transfer	Includes the functions for downloading of data in different ways.
Settings	Here you have the different settings
Monitor setup	Here you have the different setups for the PC-Mon and the sensors.

Monitor setup

This chapter is for the producer and different set ups.

<i>PC-Mon</i>		Tuesday 14 January 12:19
		Setup menu
		← Back
		Setup from disk
		Setup to disk
		Language
		Load Logo
		Set company name
		Sensor setup
Setup from disk		Sensor calibration
Setup to disk	Download of the installed specifications for your rig type.	I/O display
Language	A selection of the different communication languages available in your PC-Mon.	System info
Load logo	There are possibilities for different logo-types at the start page. Also different screensavers can be installed.	Set unique id
		Burn in test

Set company name

Type our own company name. This will be presented in the head of every data file.

Sensor setup	<p>Setup for the different transducers and sensors used on the specific rig.</p> <p>For CPTU, the reference for the pore pressure sensor can be changed between Vacuum (Absolute), and Atmospheric (Relative). Using Relative, the readings start from zero which is the current atmospheric pressure when the cone is initiated.</p>
Sensor calibration	<p>Calibration of the different transducers and sensors used on the specific rig. For CPTU, only two sensors can be calibrated: 1) The depth sensor and 2) the pressures sensor for total load if any.</p>
I/O display	<p>Shows all un calibrated data from the transducers and sensors installed on the specific rig.</p> <p>.</p>
Set unique id	<p>Puts an internal number on every file.</p>
Burn in test	<p>This is used for the final long term test of all functions of the data logger.</p>

Settings

<i>PC-Mon</i>	Tuesday 14 January 12:19
	Settings menu
	← Back
	Backlight level
	Colours
	High/Low limits
	Date and time

Back

This choice takes you back to the previous picture.

Colours

There are two ways of having the screen set up. The default with dark letters and markings on the light screen or a dark background with lighter letters. The choice is individual . In different light conditions you can achieve better visibility by changing between these two options.

Date and time

set year
select month
set date
select day
set hour
set minutes

Data transfer

<i>PC-Mon</i>		Tuesday 14 January 12:19						
<table border="1"><tr><td>Choose method</td></tr><tr><td>← Cancel</td></tr><tr><td>Not downloaded</td></tr><tr><td>From a project</td></tr><tr><td>From a date</td></tr><tr><td>From internal id</td></tr></table>		Choose method	← Cancel	Not downloaded	From a project	From a date	From internal id	← Back
		Choose method						
		← Cancel						
		Not downloaded						
		From a project						
		From a date						
From internal id								
Disk								
Modem → Modem								
Modem → email								

Back

Takes you back to the main menu.

Disk

Down load the data to disk.

Cancel	Takes you back to the main menu
Not downloaded	When a sounding has been downloaded once, it gets a mark on the file. This choice will download all files that has not been downloaded before.
From a project	When starting a new sounding up the PC-Mon asks for a Project name. This choice search the entire hard disk drive for all soundings made under the same project name.
From a date	When starting a new sounding the date will always be included in the file. This choice search the entire hard disk drive for all soundings performed on a specific date.
From internal id	Every sounding gets an internal number, starting from 0001. If the operator knows this internal number, this sounding can be downloaded again.

System function

<i>PC-Mon</i>	Tuesday 14 January 12:19
	System menu
	← Back
	Soundings directory
	Open floppy hatch
	Closing floppy hatch

Soundings directory

From this option you download soundings stored in the hard disk drive.

The choices are:

Latest, where you get the last 20 soundings listed.

From a project, where you write in the project name using the wheel on the keyboard on the screen.

From a date, where you write in the date following the instructions coming up on the screen.

Setup for CPT with the ENVI MemoCone II.
PC-Mon Data logger.

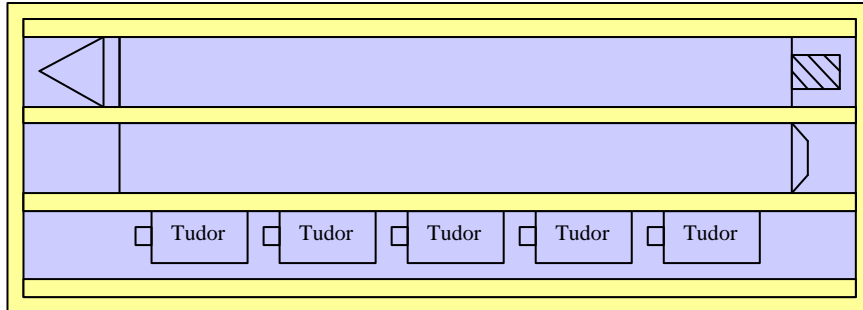

The ENVI MemoCone II Piezocone.

A complete setup for performance of CPT using the ENVI MemoCone II Piezocone consists of:

Datalogger PC-mon or C-Mon

Depth transducer DRR.

Prepared points, O-rings, Grease and oil

5 pcs of ALKALINE batteries size C (LR14).

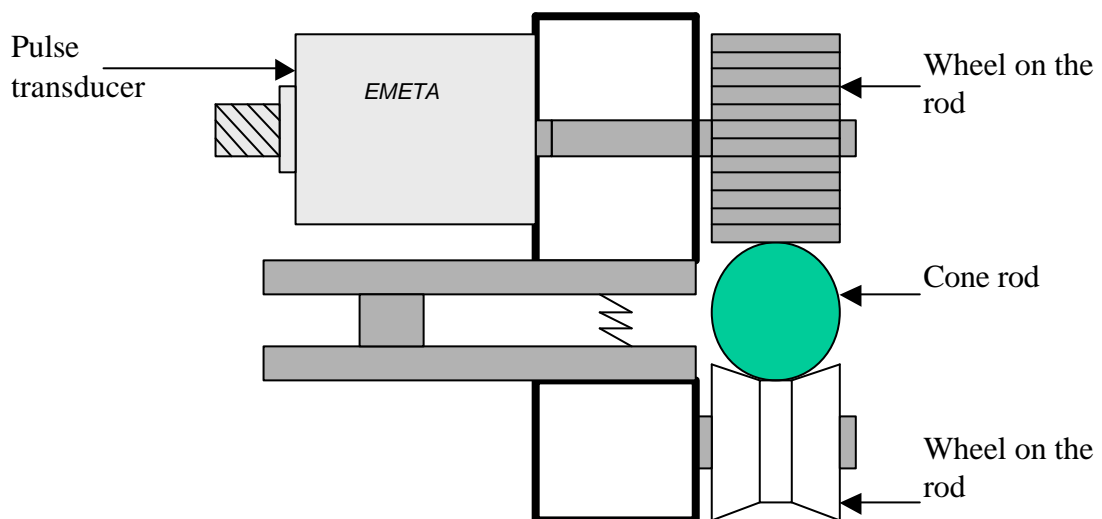

Depth registration "wheel on the rod".

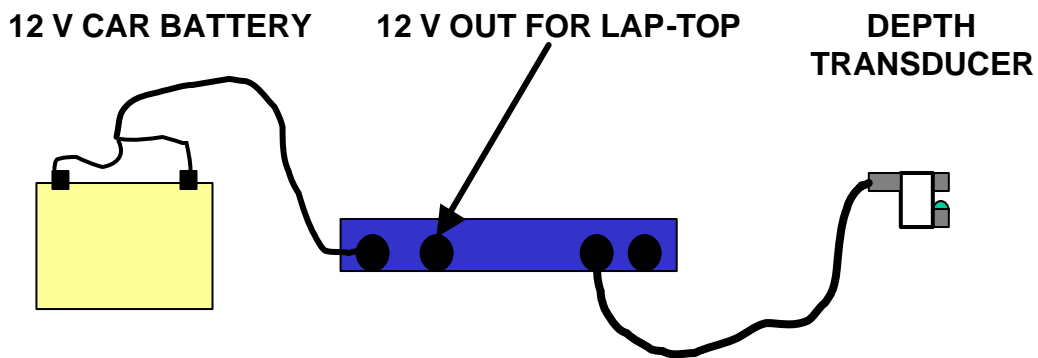

Connect 12 Volts to the 5 pole plug to the left of PC-mon back side.

Connect the Depth transducer to the 6-pole plug, second from the right.

Connect the MemoCone II between the 10 –pole LEMO plug in the middle of the PC-mon front side and the MemoCone III using the Lemo-Lemo cable.

Go to SOUNDING and choose CPT (Memory)

Input all data and you will see the following picture:

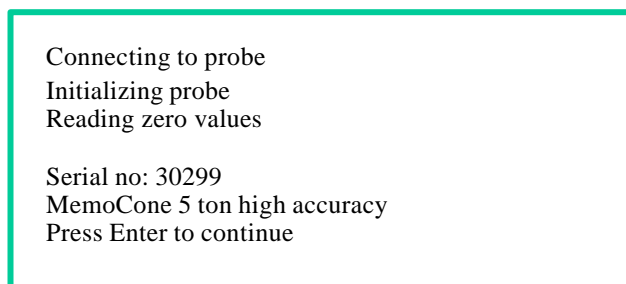

When you read the following message: **Disconnect cone and start penetration**

Disconnect the Memocone and proceed from page 16

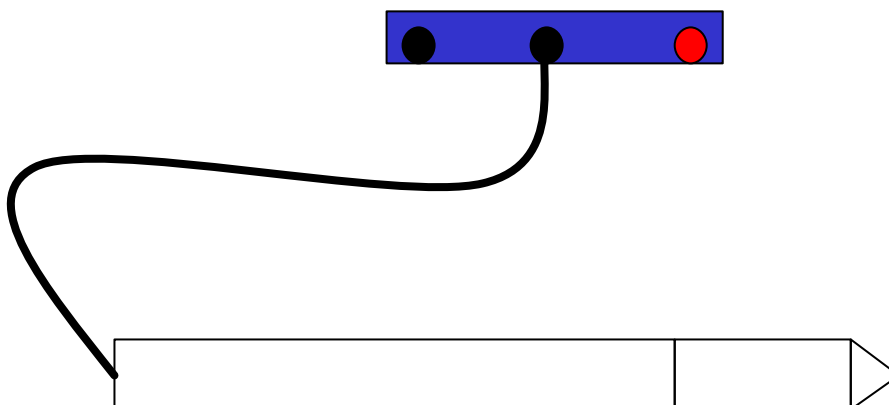

CPT with acoustic data transmission.

MemoCone III

For real time acquisition you can use the acoustic option.

It consists of a sound transmitter, instead of the battery tube, a sound receiver and a microphone.

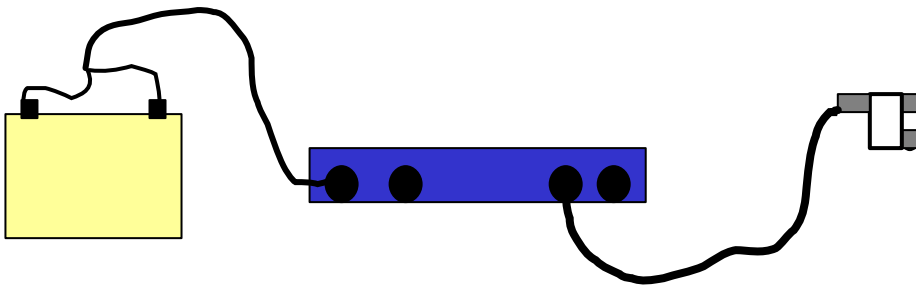

Connect 12 Volts to the PC-mon.

Connect the Depth transducer to the 6-pole plug, second from the right.

Connect the microphone cable between the microphone and the BNC plug in the left side of the PC-mon.

Connect the MemoCone II between the 10 –pole LEMO plug in the middle of the PC-mon and the MemoCone III using the Lemo-Lemo cable.

Install the microphone on the pushing head and push on top of the rods with the microphone.

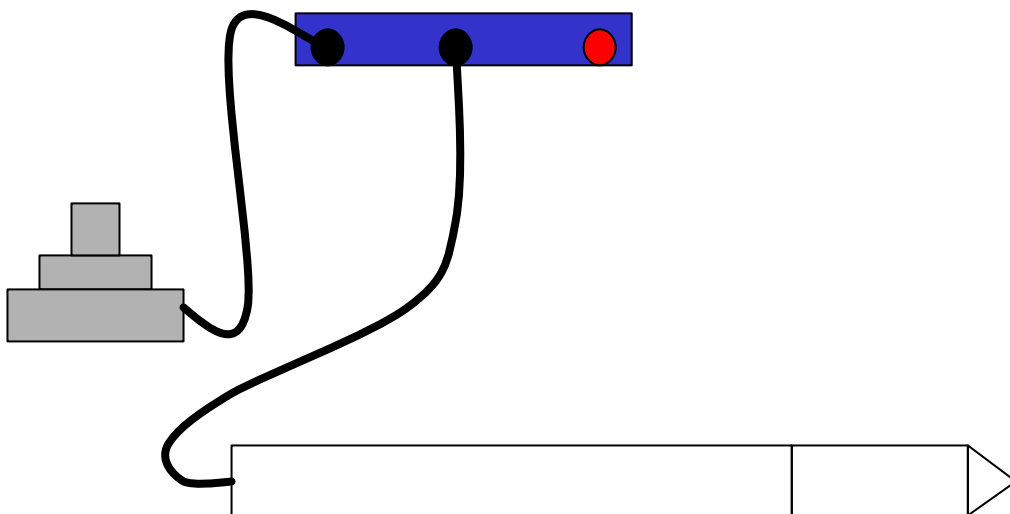

Go to Sounding and press ENTER

<i>PC-Mon</i>		Tuesday 14 January 12:19
		Main menu
Choose sounding method		Sounding
← Back		System function
CPT (memory)		Data transfer
CPT(acoustic)		Settings
Memocone re-dump		Monitor setup
CPT (cable)		

Choose CPT (acoustic)

Preparation of the ENVI MemoCone III.

MemoCone
Conical filter point
Universal spanner
Grease
Hydraulic oil
Cable

Start by filling the conical filter point with grease. Make sure the filter point is entirely filled with grease and that there are no air bubbles in the point. Press grease into the filter point until you can see it coming out from the slot. Wipe away excessive grease.

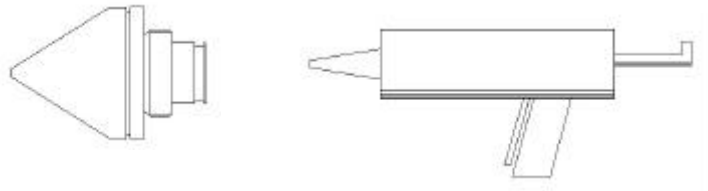

Fill the cavity in the lower part of the MemoCone with hydraulic oil and remove the air bubbles which are formed in the oil.



Then place the filter point into the MemoCone. Lean the point slightly to avoid air bubbles.

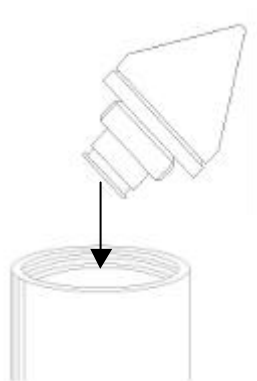

Place two O-rings behind the conical filter and one O-ring on the other end of the friction sleeve. Tighten the conical filter slightly using a universal spanner.

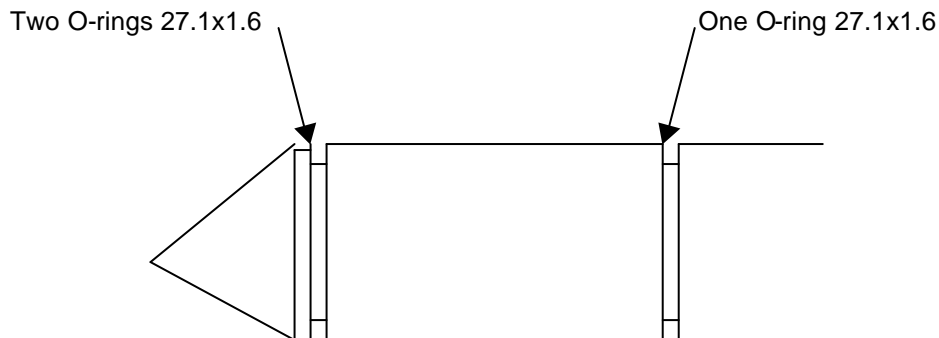

The MemoCone is now ready for sounding and can be stored "prepared" for several hours without affecting the measurement.

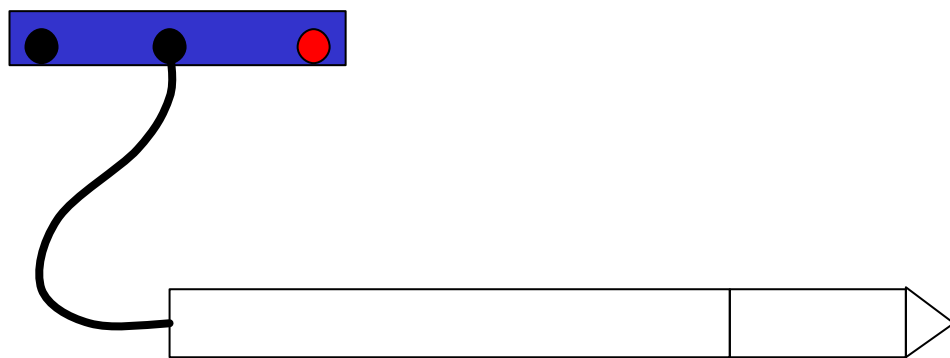

Connect the MemoCone III to the LEMO plug in the centre

Go to CPT acoustic in the SOUNDING MENU

```
Connecting to probe
Initializing probe
Reading zero values

Serial no: 30299
MemoCone 5 ton high accuracy
Press Enter to continue
```

If readings of zero values are presented on the screen, it indicates that the values are outside the accepted.

DISCONNECT:

When this picture is shown on the screen, disconnect the cable from the MemoCone and put the **BATTERY PLUG** in the MemoCone instead of the cable.

Put five **ALKALINE** batteries, model Size C, 1,5V, in the battery tube, with the plus pole pointing **DOWNWARDS** when the cone is mounted and positioned to start the test. Don't use rechargeable batteries.

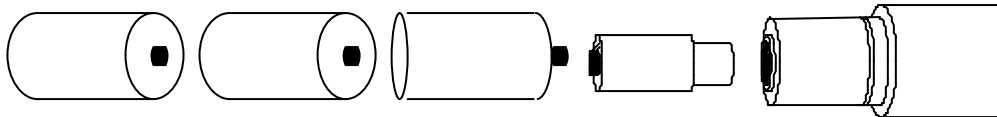

Screw the MemoCone and the battery tube together, but not completely. You should be able to watch the two lamps just inside the thread. A steady twinkling of the **green** lamp ensures that the MemoCone has started to take readings, If the **red** lamp is on, it means that the battery is poor and not good for a test. If the **green** light is twinkling **1 sec. ON – 1 sec. OFF**, screw together tight. A “ticking” sound should be heard. The MemoCone is now ready for pushing.

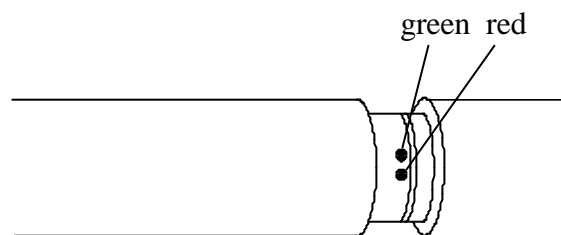

Press ENTER

If you start the test from the surface, just press ENTER.

If the hole is pre drilled through dry crust or fill, put in the pre drilled depth.

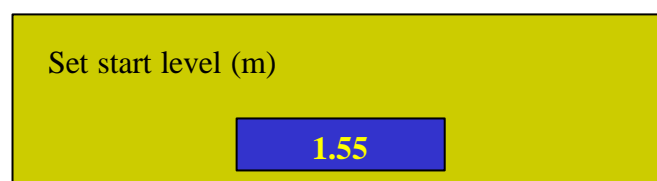

Enter project name	
← <input type="text" value="ES"/> 123456▼7890+-.@ ▼ ÅÄÖ	←
← ABCDEFG▲HIJKLMNQP▲QRSTUVWXYZ	←
ChiangiAirport	

When the project name is written go to  and press ENTER.

The selected project name will now be registered in the head of the data file.

For the next sounding this project name will be suggested as default.

If the project name shall be changed go to  and erase the chosen name and type the new project name as described above.

Positioning of the sounding.

Select type of
No id
XYZ coordinates
Line, offset
Cancel sounding

If choosing:

- No id: The PC-mon jumps direct to reading zero values
- Free id: Use the key board to print your bore hole number
- XYZ coordinates: Use the key board to register first the X coordinate, than the Y coordinate and last the Z coordinate. For the changes use the ↵
- Centre line, offset: Use the key board to register centre line
Use the key board to register offset and Z coordinate

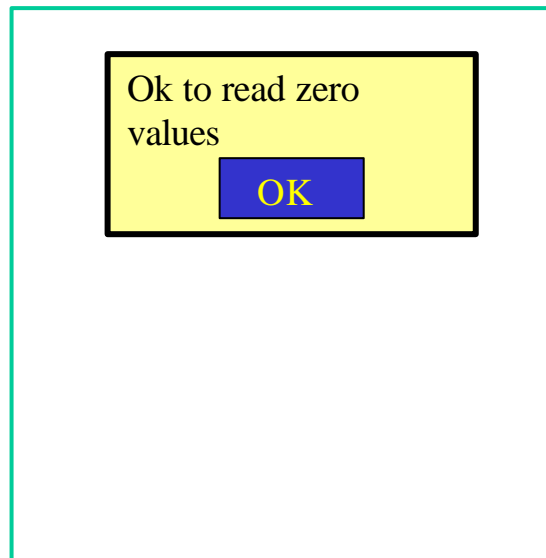

Push ENTER for OK.

The PC-Mon puts the zero values in the data file as zero values before sounding.

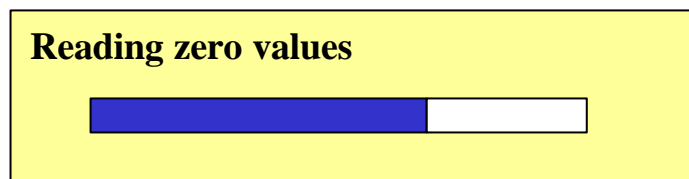

The screen on the PC-Mon changes to this picture while sounding.

QC (MPa) 0.000	U	FS	CPT acoustic mode
FS 0.000	QC		End sounding
U (MPa) 0.100			Set scales
Incl. N/A			Comment
			Discard sounding
Force (kN) 0.00			
ROP (m/min) 1.20			
Depth (m) 0.00			
	0 – 1 MPa 0-10 MPa	0 – 1 MPa	

Place the MemoCone in the machine and start pushing.

NOTE : when the cone is starting to move, **PUSH** the **DEPTH SYNC START BUTTON**. The red light goes out and the registration starts.

If you have the depth transducer that moves up and down with the machine, the button must be pushed at every rod shift, to make the registration collected in the PC-Mon.

If you have a depth transducer of the “wheel on the rods” type this will not be necessary. In this case only push once, when you start the penetration.

In order to protect the MemoCone from being overloaded, please do not use total load higher than indicated in the table below:		
Depth	10 ton cone	5 ton cone
0-10m	10 tons	5 tons
10-20m	13 tons	8 tons
20-30m	18 tons	11 tons
>30m	20 tons	16 tons

Downloading the data from ENVI MemoCone II & III

When using the acoustic transmission, you will get real time data that is also saved in the memory. This data can however sometimes be disturbed and affected in such a way that it may be incomplete.

In order to get perfect undisturbed data from the memocone, connect the cone once again to the PC-mon and download the data from the memory as follows:

After retraction of the cone, take the cone from the machine and unscrew the battery tube. Connect the cone as described on page 12.

Select "End sounding" on the screen

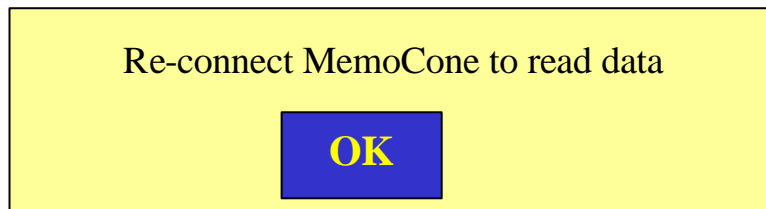

Choose OK by pressing ENTER

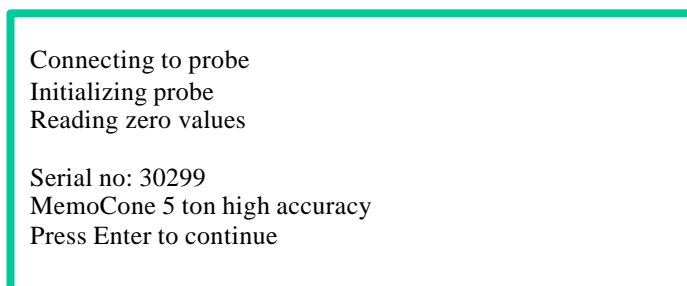

If readings of zero values are presented on the screen, it indicates that the values are outside the accepted.

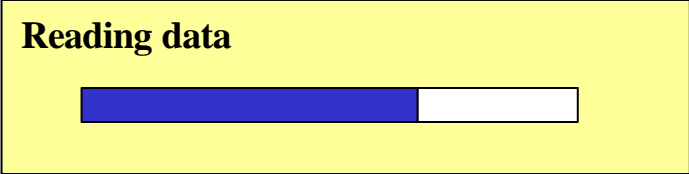

All the stored data is now transferred from the MemoCone to the PC-Mon and is presented on the screen.

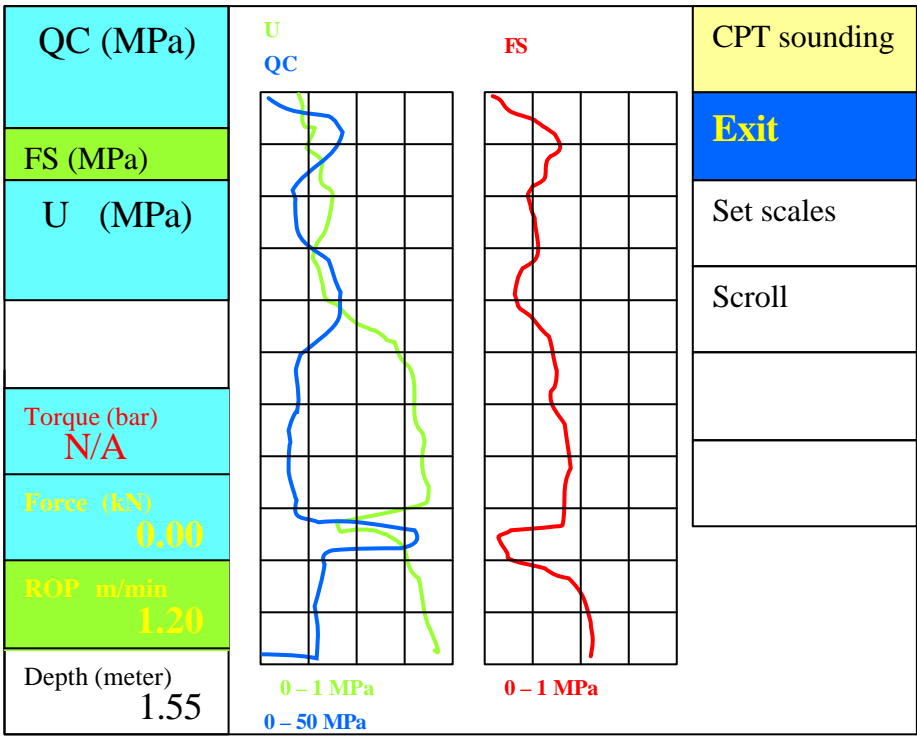

DISSIPATION TEST (Memory operation)

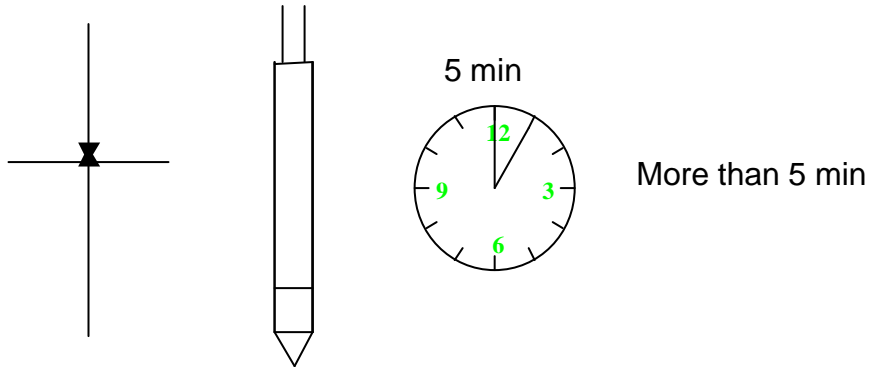

STOP PENETRATION

WAIT > 5 MINUTES

NOTE: The maximum operation time for the Memocone III is 8 hours.

You can follow the decay of the pore pressure on the screen.

To stop the dissipation test, just continue the penetration.

Of course you can make more dissipation tests further down. If you want to terminate the penetration and make a dissipation test, you must stop the dissipation test before pulling up.

This is done by **continuing the penetration a few centimetres.**

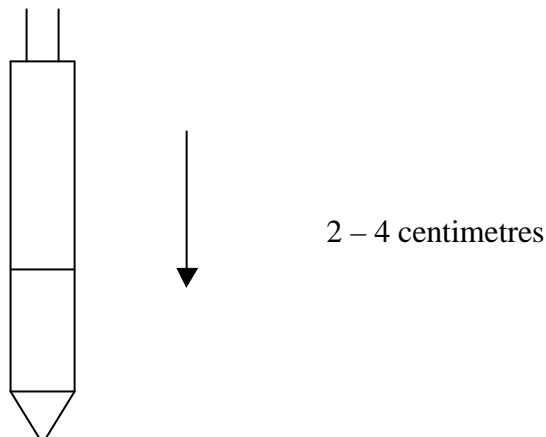

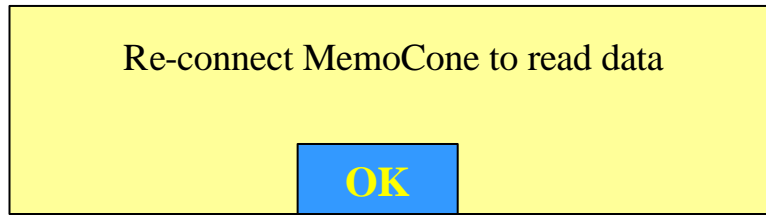

The MemoCone downloads the zero values, all the CPT data, presents it as graphs.

After this the dissipation test (s) is downloaded.

Put in the project name and type of id.

The test level/s is/are written on the screen.

Test level 32.00 (meter)	Time	U_t	Dissipation
	01:50	0.315	Exit
	01:25	0.325	Scroll
	01:06	0.335	
	00:29	0.361	
	00:22	0.349	
	00:16	0.394	
	00:11	0.431	
	00:08	0.365	
	00:05	0.333	

The file can be plotted in any kind of plotting software like "Opensounding" or CPT PRO

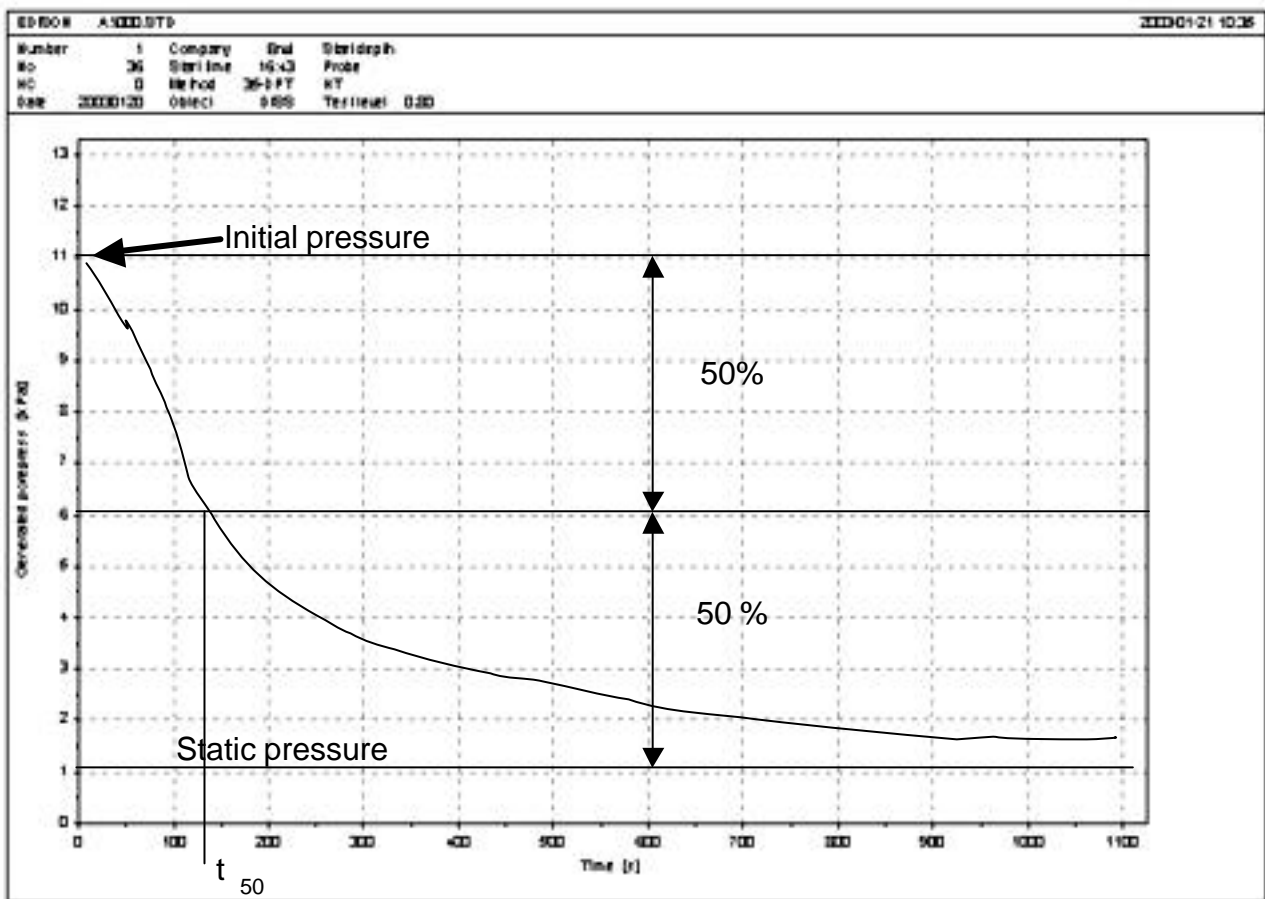

Downloading data from the PC-Mon to DISK.

Choose down loading method
← Cancel
Not downloaded
From a project
From a date
From internal id

Choose the method for downloading and press ENTER.

Now you can select the required data format:

Select data format
STD format
Text format

STD format is a standardized format used within the geotechnical and geological branch in Scandinavia.

Text format is the international ASCII format for i.e. EXCEL.

MAINTENANCE of the MEMOCONE

After every test:

- Displace the friction sleeve about 20 mm downwards by gentle rotating and pulling.
- Use a toothbrush and clean up the upper and lower joints.
- Smear with grease.
- Push and rotate the Friction sleeve gently back into position.
- Put the O – ring back into position

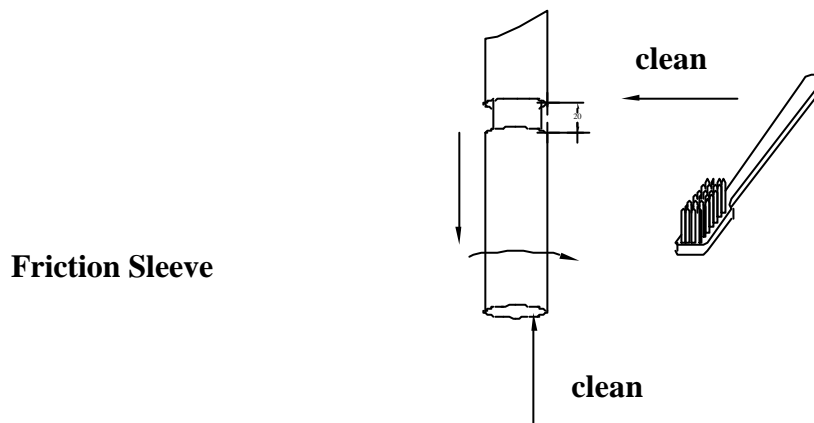

After the completed project:

•Remove the friction sleeve completely, clean and grease. Remove the ring from the conical filters and clean them with compressed air.

Smear the complete probe and battery tube (steel tubes) with oil before storage. Grease all O-rings.

Users manual for CPT in cable mode.

PREPARATIONS:

MemoCone
Conical filter point
Universal spanner
Grease
Hydraulic oil
Cable

Start by filling the conical filter point with grease. Make sure the filter point is entirely filled with grease and that there are no air bubbles in the point.

Press grease into the filter point until you can see it coming out from the slot on the filter point. Wipe away excessive grease.

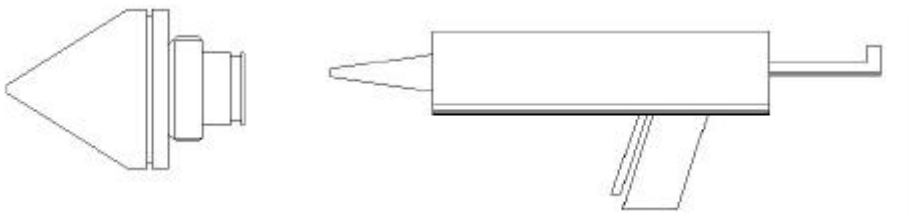

Fill the cavity in the lower part of the MemoCone with hydraulic oil and remove the air bubbles which are formed in the oil.



Then place the filter point into the MemoCone. Lean the point slightly to avoid air bubbles.

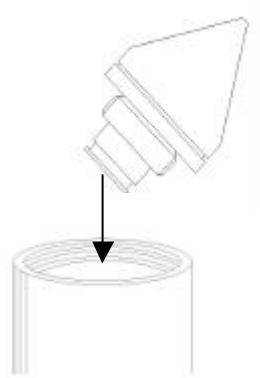

Place two O-rings behind the conical filter and one O-ring on the other end of the friction sleeve. Tighten the conical filter slightly using a universal spanner.

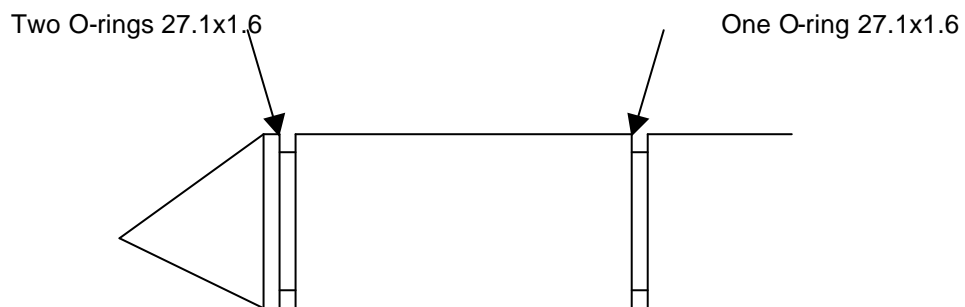

The MemoCone is now ready for sounding and can be stored "prepared" for several hours without affecting the measurement.

CABLE CONNECTIONS:

1. Connect the **CABLE** to the terminal B
2. Tighten the **GLAND A**
3. Fill with **OIL** in the **BRASS TUBE C** up to level **D**
4. Put on the brass tube and lock the bayonet
5. Screw on the **STEEL TUBE E**
6. Connect the MemoCone and rotate 6 turns counter clockwise
7. Screw together

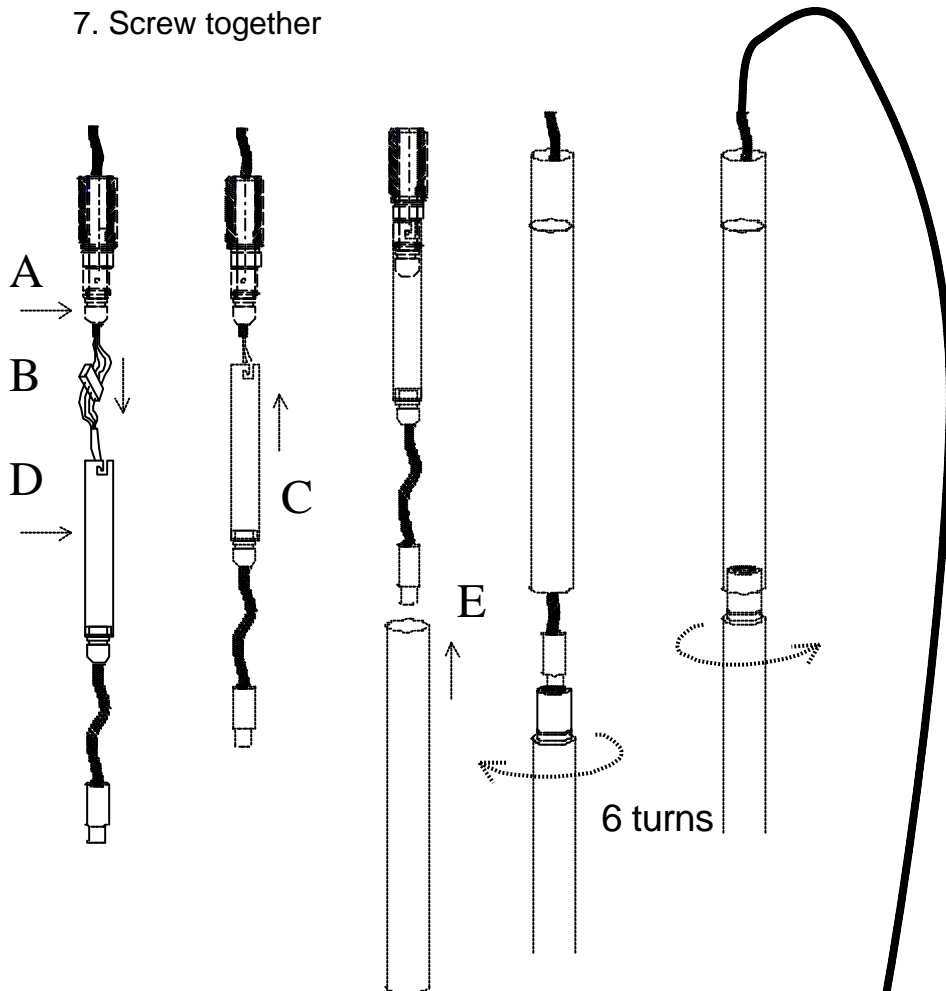

Connect the cable to the plug in the front of the PC-Mon.

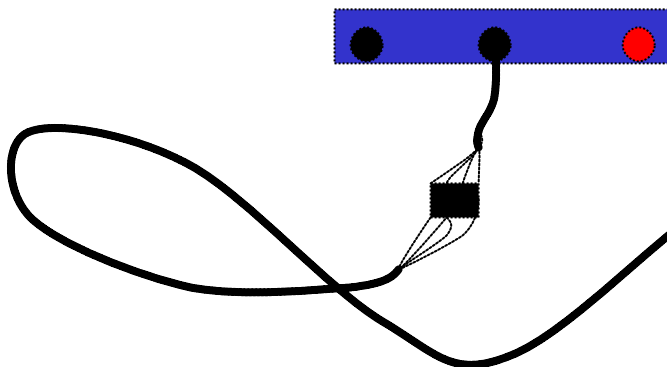

<i>PC-Mon</i>		Tuesday 14 January 12:19
<div style="border: 1px solid black; padding: 5px; margin: 10px auto; width: 80%;"> <div style="background-color: yellow; padding: 2px; text-align: center;">Choose sounding method</div> <div style="padding: 2px; text-align: center;">← Back</div> <div style="padding: 2px; text-align: center;">CPT (acoustic)</div> <div style="padding: 2px; text-align: center;">CPT (memory)</div> <div style="background-color: blue; color: yellow; padding: 2px; text-align: center;">CPT (cable)</div> <div style="padding: 2px; text-align: center;"> </div> <div style="padding: 2px; text-align: center;"> </div> </div>		Main menu
		Sounding
		System function
		Data transfer
		Settings
		Monitor setup

Go to CPT (cable) and push ENTER.

Connecting to probe
 Initializing probe
 Reading zero values

Serial no: 30299
 MemoCone 5 ton high accuracy
 Press Enter to continue

If readings of zero values are presented on the screen, it indicates that the values are outside the accepted.

Screw the MemoCone and the cable tube together, but not completely. You should be able to watch the two lamps just inside the thread.

A steady twinkling of the **green** lamp ensures that the MemoCone has started to take readings.

When the **green** light is twinkling **1 sec. ON – 1 sec. OFF**, screw together tight, The MemoCone is now ready for pushing.

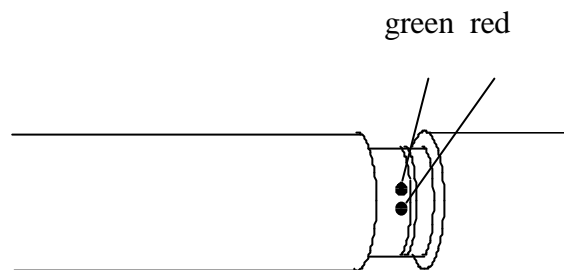

Press ENTER

If you start the test from the surface just press ENTER again.

If the hole is pre drilled through dry crust or fill put in the pre drilled depth by rotating the wheel and push the button.

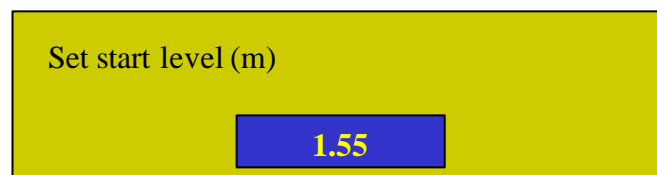

Enter project name	
← [ESC] 12345 7890+-.@ ▼ ÅÄÖ	←
← ABCDEFG▲HIJKLMNQP▲QRSTUVWXYZ	←
ChiangiAirport	

Use the wheel as a joy stick and go between the letters, symbols and numbers. Confirm the letter with the centre button.

When the project name is written go to ← and press ENTER.

The selected project name will now be registered in the head of the data file.

For the next sounding this project name will be suggested as default.

If the project name shall be changed go to ← and erase the pre chosen name and type the new project name ← as described above.

Positioning of the sounding.

Select type of
No id
Free id
XYZ co-ordinates
Line, offset
Cancel sounding

If choosing:

- No id: The jumps directly to reading zero values
- Free id: Use the key board to print your bore hole number
- XYZ coordinates: Use the key board to register first the X coordinate, than the Y coordinate and last the Z coordinate. For the changes use the ↵
- Centre line, offset: Use the key board to register centre line
Use the key board to register offset and Z coordinate

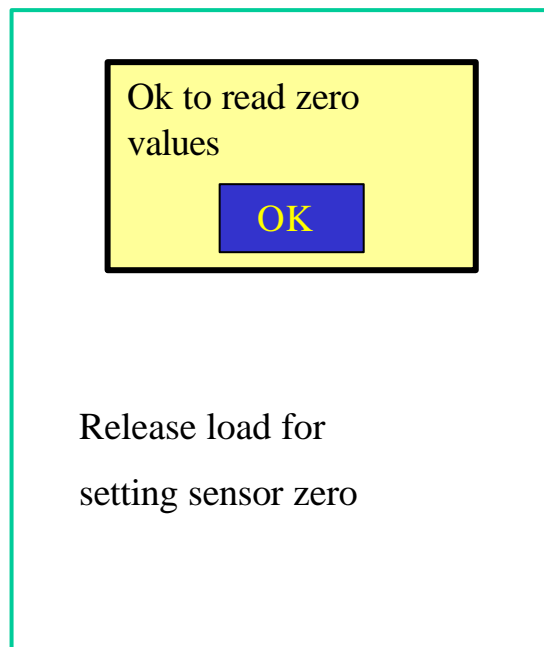

Push ENTER for OK.

The PC-Mon puts the zero values in the data file as zero values before sounding.

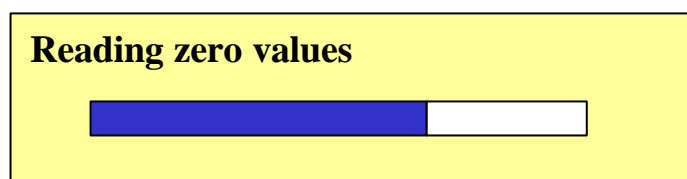

Starting the penetration.

Place the MemoCone in the machine and start pushing.

OBSERVE: when the cone is starting to move, **PUSH** the **DEPTH SYNC START BUTTON**. The red light goes out and the registration starts.

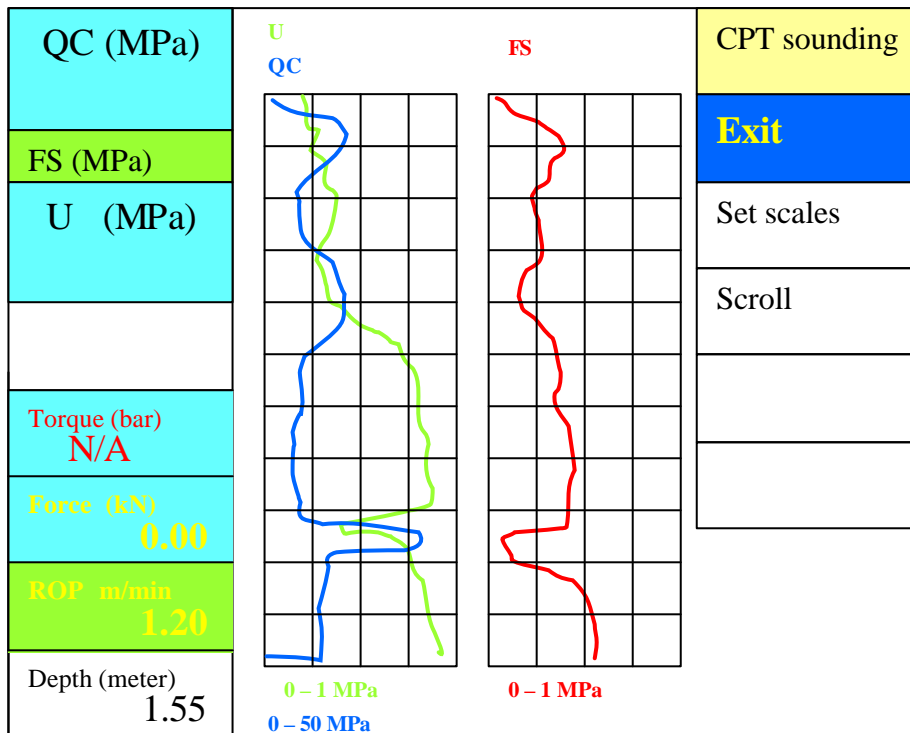

Stop the CPT test.

Use the **UP/DOWN ARROWS**, go to End sounding and push **ENTER**.

The PC-Mon reads the zero values after the test and stores all data in the hard disk drive.

Downloading data from the PC-Mon to DISK.

Choose down loading method
← Cancel
Not downloaded
From a project
From a date
From internal id

5. Choose the method for downloading and press ENTER.
Now you can select the required data format:

Select data format
STD format
Text format

STD format is a standardized format used within the geotechnical and geological branch in Scandinavia.

Text format is the international ASCII format for i.e. EXCEL.

MAINTENANCE of the MEMOCONE

After every test:

- Displace the friction sleeve about 20 mm downwards by gentle rotating and pulling.
- Use a toothbrush and clean up the upper and lower joints.
- Smear with grease.
- Push and rotate the Friction sleeve gently back into position.
- Put the O – ring back into position

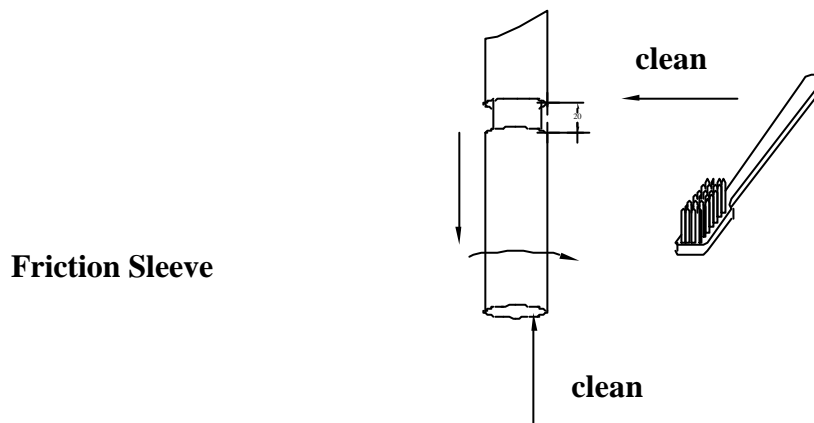

After the completed project:

•Remove the friction sleeve completely, clean and grease. Remove the ring from the conical filters and clean them with compressed air.

Smear the complete probe and battery tube (steel tubes) with oil before storage. Grease all O-rings.

The DATA file.

There are two major formats for the drilling parameter data file:

1. STD type file for evaluation programs: EDISON and CPT PRO

```
$
HA=1,HB=80,HC=ENVI-0,HO=0.03,HD=19930902,HM=60,HJ=peabs4,HF=PEAB
#
D=0.03,A=0,B=245.5I=0,G=0,R=67,P=0.3438
D=0.04,A=0,B=255.83,I=0,J=0.73242,G=0,R=67,P=0
D=0.07,A=0,B=240.67,I=0,J=0.48828,G=0,R=67,P=1.5625
D=0.08,A=0,B=219.17,I=0,J=0.24414,G=0,R=67,P=1.5625
D=0.1,A=0,B=144.33,I=0,J=0,G=0,R=67,P=1.5625
D=0.12,A=0,B=39.5,I=0,J=0.73242,G=0,R=67,P=0.78125
D=0.14,A=6.748,B=0.5,I=0.84529,J=2.4414,G=45.41,R=67,P=6.9531
D=0.16,A=7.8455,B=72.5,I=0.85027,J=2.4414,G=52.49,R=0,P=8.0273
D=0.18,A=5.6504,B=95.833,I=0.84529,J=2.1973,G=59.326,R=0,P=7.6758
D=0.2,A=6.8293,B=133.33,I=0.83038,J=2.4414,G=66.162,R=70,P=6.9531
```

2 TXT type of file (for ECXEL etc.):

```
$
HA=1,HB=1,HC=ENVI-79,HO=19970429,HI=10:20,HM=60
#
DEPTH BITLOAD ROP F PRESS FLOW RPM TORQUE CODE TEXT
0.02 20.081 36.5 0.0198 0.0011 0 7.7615
0.04 20.081 28.5 0.0198 0.0011 0 7.7615
0.06 20.122 32.4 0.0198 0.0011 0 7.7615
0.08 20.122 29.0 2.0336 0.0011 0 7.7615
0.10 20.081 29.7 4.8624 7.1782 13.3 7.7615
0.12 20.122 172.83 7.4465 13.772 44.8 7.7615
0.14 18.855 170.5 5.9786 15.99 67.8 7.7615
0.16 18.033 167.88 6.1009 17.371 85.5 8.2111
0.18 16.432 169.0 6.1009 19 88.3 11.691
0.20 16.011 171.446.1009 19.856 88.9 13.685
```

LEGEND:

Heading

HA = No of heading
HB = Serial No of registration
HC = Serial No of data collector
HD = Date
HI = Start time for registration
HM = Method code
HF = Company name
HJ = Name of object
HL = Section
HH = Deflection to the right of section centre
HV = Deflection to the left of section centre
HK = No of registration given in the field
HT = Text
HN = Number of probe

Data:

D = depth in metres
K = 2 digit codes
T = Text string
A = Bit load in kN
B = Rate of penetration (ROP) in mm/s
F = Local friction (CPT)
Q = Point resistance (CPT)
U = Generated pore pressure (CPT)
J = Flow in to the borehole of flushing medium in l/min
G = Flow out of the borehole of flushing medium in l/min
I = Pressure of flushing medium in MPa
P = Rotation motor pressure (torque)
R = Rotation speed (rpm)
S = Number of blows per 0.2 meter
AZ = Hydraulic pressure on drifter/hammer

Appendix A: Microphone pushing head.

The microphone pushing head will detect the small sound waves in the CPT rods coming from the Memocone III CPTU probe. Inside the microphone, there is a crystal unit that will convert the sound signal into an electric voltage signal which is connected to the receiver unit in the C-mon. When a usable signal is detected, the LED in the receiver unit will light up for every reading received. Since the full force of the CPT pusher (200kN) is transferred through the aluminum body of the microphone unit, it is important that it is installed in a correct way.

Installation of the microphone in the CPT pusher:

The picture below shows a recommended installation.

The microphone will fit into a circular piece of steel with an inner hole of 70mm diam. and a height of at least 55 mm.

The unit will automatically hatch into the steel piece with the help of small magnets.

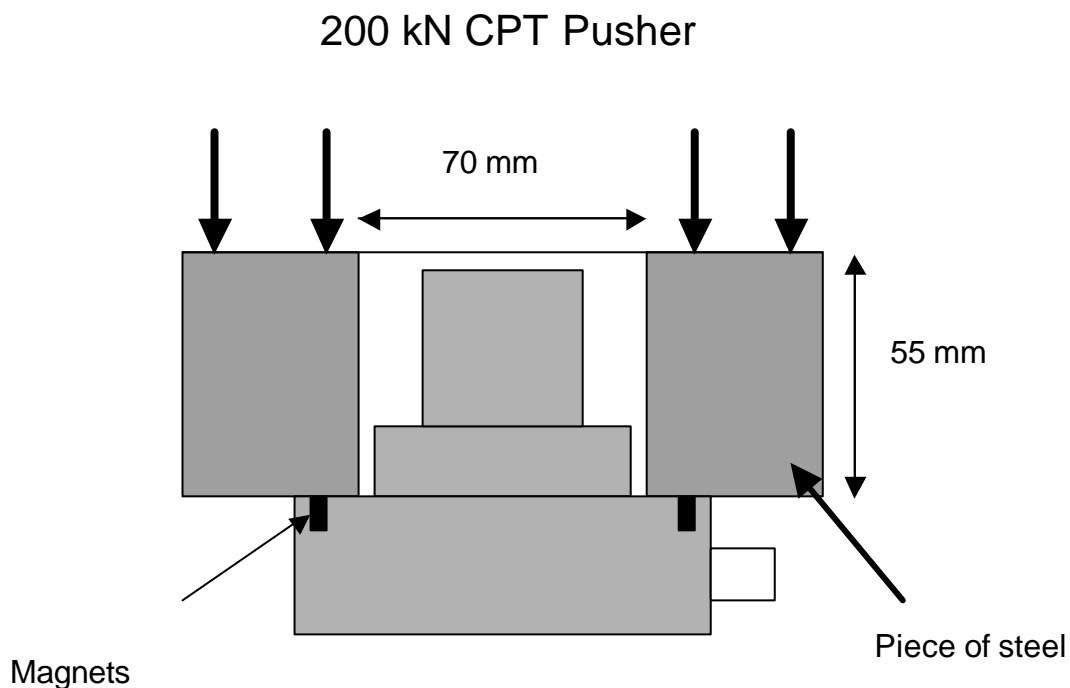

In case of trouble, fault detection schedule

<p>1. The PC-mon does not light up or show any sign of power.</p>	<p>Check if the PLUS POLE of the 12 Volt battery is connected to the power cable with RED mark. Check the 4 Amp Fuse at the rear.</p>
<p>2. The PC does not communicate with the PC-mon.</p>	<p>The USB communication cable must be connected and the correct COM port number set in the PC software.</p>
<p>3. No registration of depth</p>	<p>Check that the Depth transducer is connected to the PC-mon. The software will only registrate depth if you have pushed the DEPTH SYNC START button so that the red light inside this button is OFF.</p>
<p>4. Depth registration works the wrong way.</p>	<p>Go to SET UP and SENSOR SET UP – DEPTH. Change the setting NORMAL / INVERSE</p>
<p>5. PC-Mon Software cannot find the Interface unit after PC has returned from Sleep, Standy, Hibernation</p>	<p>Shutdown and Restart Windows. When doing CPT soundings, please disable Windows from automatically entering Sleep, Standby, Hibernation mode. This can usually be configured in Control Panel, Power settings</p>
	<p style="text-align: right;">41</p>